



-power in control



## DATA SHEET



### **Rudder/azimuth angle Transmitter Analogue, RTA 602**

- Analogue output 4 to 20 mA
- Drives one or more indicators
- Programmable angle up to +/-180 °
- Easy zero and max./min. adjustm.
- Continuous shaft rotation



DEIF A/S · Frisenborgvej 33 · DK-7800 Skive  
Tel.: +45 9614 9614 · Fax: +45 9614 9615  
info@deif.com · www.deif.com

Document no.: 4921250068B  
SW version:

<b>1. General information</b>	
1.1. Product description.....	3
<b>2. Technical information</b>	
2.1. Technical specifications.....	4
2.2. Driving capability.....	5
2.3. Rudder system, MED approval.....	5
2.4. Azimuth system.....	5
2.5. Applications - rudder and azimuth systems.....	6
2.6. Unit dimensions and wiring.....	6
2.6.1. Unit dimensions in mm.....	6
2.6.2. RTA 602 with bracket.....	7
2.6.3. Wiring of RTA 602 .....	8
<b>3. Ordering information</b>	
3.1. Available variants.....	9
3.2. Available accessories.....	9
3.3. Order specifications and disclaimer.....	10
3.3.1. Order specifications .....	10
3.3.2. Disclaimer.....	10

# 1. General information

## 1.1 Product description

The RTA 602 is a very robust angle sensor intended for marine applications like high accuracy rudder, azimuth or pitch angle measurements. It may also be suitable for other applications.

All DEIF angle sensors are based on a "no touch" measuring principle, ensuring a long life without degradation of performance or accuracy due to wear and tear of electro-mechanical components such as potentiometers.

The RTA 602 provides a standard 2-wire 4 to 20 mA analogue output, meaning that it is supplied by the measuring signal and that no additional auxiliary power source is needed for the sensor itself.

The RTA 602 is mechanically compatible with the DEIF RT-2 rudder angle transmitter; even though the RTA 602 housing is slightly smaller than that of the RT-2, the mounting holes and shaft dimensions are the same.

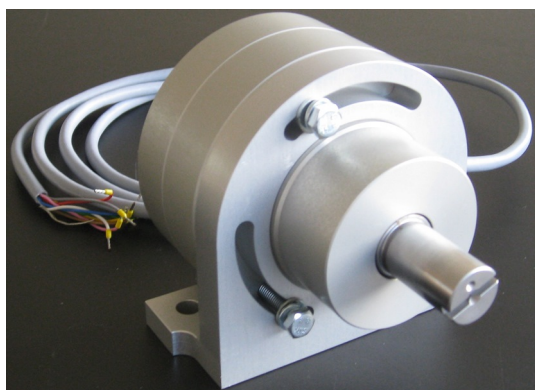

RTA 602 with 90 deg. mounting bracket



RTA 602 without mounting bracket

The RTA 602 is very accurate and can be precisely calibrated after installation. Performing the three-point calibration procedure will provide excellent calibration linearity of the system.

The normal way of calibrating the RTA 602 is by first setting the centre position (12 mA), then the min. angle (4 mA) and the max. angle (20 mA) using the programming wires.

In some installations it may be difficult or impossible to bring the sensor into its absolute maximum and minimum position; in this situation the half scale calibration function is used instead.

### Example:

A rudder system is physically limited to  $\pm 38$  deg. and uses a DEIF XL rudder indicator with  $\pm 45$  deg. scale and 4 to 20 mA input. To calibrate this system, the half scale calibration function is used. After setting the zero point, the rudder is placed physically in 22.5 deg. port (= half of the indicator's 45 deg. scale) and the half scale (8 mA) calibration function is performed, followed by calibration of the half scale starboard side (16 mA) in the same way.

The default rotation direction is clockwise (CW), where turning the shaft clockwise increases the output current. Using other programming by wire functions, it is possible to set zero and at the same time shift the rotation direction between CW and counterclockwise (CCW).

## 2. Technical information

### 2.1 Technical specifications

Transmitter type	Analogue 2-wire 4 to 20 mA
Output range	4.0 to 20.0 mA
Max. range (angle out of range)	3.8 to 20.2 mA
Operating voltage (VCC)	7.5 to 35.0 V <sub>dc</sub>
Load resistance (sum of all loads of connected input devices and cable)	Max. 500 Ω at ≥18 V supply Max. 800 Ω at ≥24 V supply (refer to the paragraph Driving capability)
Capacitive load max.	100 nF
Reverse aux. voltage protection	Yes
Measuring angle electrical	360 deg.
Rotation direction	Default clockwise (CW) seen into the shaft Programmable to counterclockwise (CCW)
Zero point at 12 mA	Freely programmable within 360 deg. *)
Angle range	Freely programmable: Recommended +/-20 deg. to +/-180 deg. Default +/-45 deg. *)
Linearity Angle span up to +/-180 deg.	Better than: ±0.25 deg.
Update rate	≥7 Hz
Hysteresis and repeatability	≤0.1 deg.
Temperature coefficient	≤100 ppm
Programming	3-wire: S1, S2 and SC (common) sequence programming <ul style="list-style-type: none"> <li>• Direction change: CW/CCW</li> <li>• Zero set</li> <li>• Full scale calibration (max./min.)</li> </ul> or alternatively <ul style="list-style-type: none"> <li>• Half scale calibration (½ max./½ min.)</li> </ul>
Output and programming wire short-circuit protection	To VCC and GND
Protection	IP67
Temperature	Operating: -40 to 80 °C Storage: -40 to 80 °C
Torque (start/rotate)	<0.25 Nm
Shaft load (axial/radial)	500 N/1000 N
Material	Housing: Aluminium Shaft: Stainless steel
Vibration	4 g, 2 to 2000 Hz all axes
Shock	50 g, half sine, 10 to 15 ms, 50 cycles

Connection	Fixed 2 m shielded cable, 5 wires (3 wires are used for programming only)
Insulation	Any wire to housing: 500 V <sub>eff</sub> , 50 Hz, 1 min.
Weight	RTA 602: 1.80 kg RTA 602 w/bracket: 2.15 kg
Approvals	Please refer to <a href="http://www.deif.com">www.deif.com</a> for an updated list of certificates
Accessory	90 deg. mounting bracket (0.35 kg) Note: Mechanically compatible with RT-2 with bracket

\*) : When the zero point is programmed by wire, the min./max. must also be recalibrated.

## 2.2 Driving capability

The RTA 602's ability to drive a high load resistance at a relatively low voltage makes it possible to make a very reliable rudder or azimuth indicator system supplied from a battery backed 24 V power supply system. This can be indicator systems with up to 10 XL indicators or, alternatively, up to seven XL indicators and one TRI-2 panorama indicator, all driven by one RTA 602.

If the supply voltage for the indicator system is stabilised and never dropping below 24 V<sub>DC</sub>, it is possible to connect an additional four to five XL indicators in the described systems and still leave room for a certain voltage drop in the cables. For more detailed information, please refer to the DEIF rudder system application notes that can be downloaded from [www.deif.com](http://www.deif.com).

## 2.3 Rudder system, MED approval

All DEIF rudder/azimuth transmitters and rudder/azimuth indicators are MED approved as a system according to ISO 20 673. Please refer to [www.deif.com](http://www.deif.com) for approval status and certificates.

Calibration accuracy when this rudder transmitter is used in a rudder system:

Example 1:

In a rudder indication system with a +/-45 deg. scale, the rudder transmitter calibration accuracy will be better than: +/-0.6 %.

Example 2:

In a rudder indication system with a +/-70 deg. scale, the rudder transmitter calibration accuracy will be better than: +/-0.5 %.

## 2.4 Azimuth system

The use of a 4 to 20 mA angle sensor in an azimuth system requires an indicator capable of filtering and presenting the analogue signal also when it is making the abrupt jump from 4 to 20 mA when the angle crosses 180 deg. All DEIF azimuth indicators for 4 to 20 mA can handle this challenge, but we recommend using the CAN bus-based DEIF RTC 300 or RTC 600 rudder/azimuth angle transmitter for this type of applications.

## 2.5 Applications - rudder and azimuth systems

For more detailed information on how to use the DEIF angle transmitters and illuminated indicators in rudder or azimuth applications, please refer to the related application notes that can be downloaded from [www.deif.com](http://www.deif.com).

## 2.6 Unit dimensions and wiring

### 2.6.1 Unit dimensions in mm

Front view

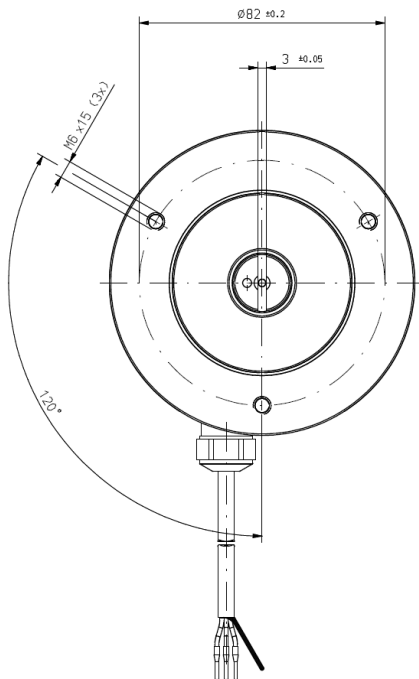

Side view

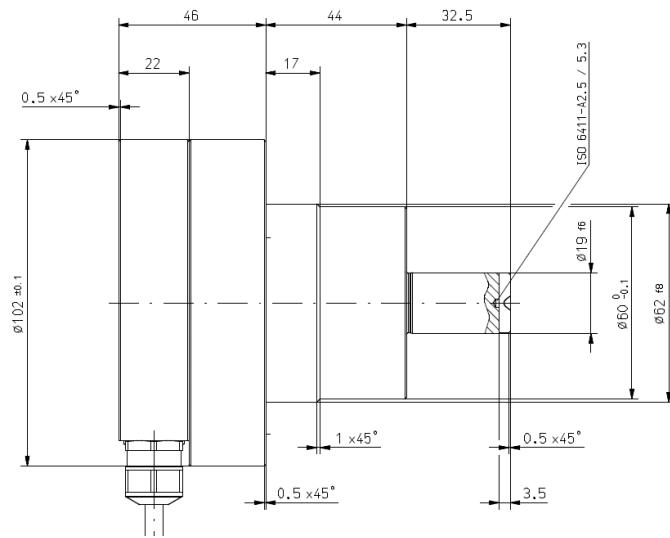

### 2.6.2 RTA 602 with bracket

The 90 degree mounting bracket for the RTA 602 is supplied separately, including the screws and washers needed for mounting.

Side view

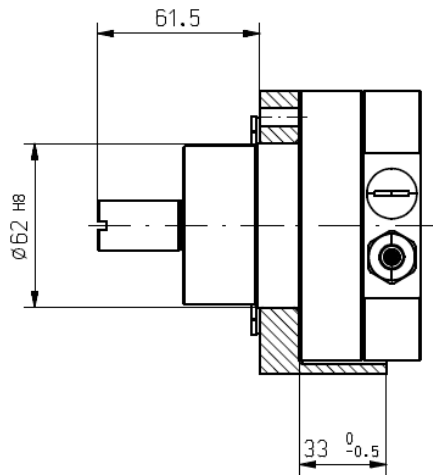

Bottom view

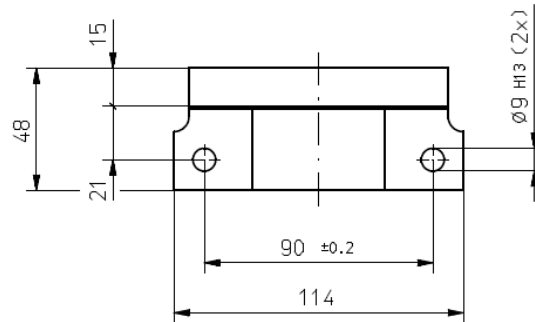

Front view

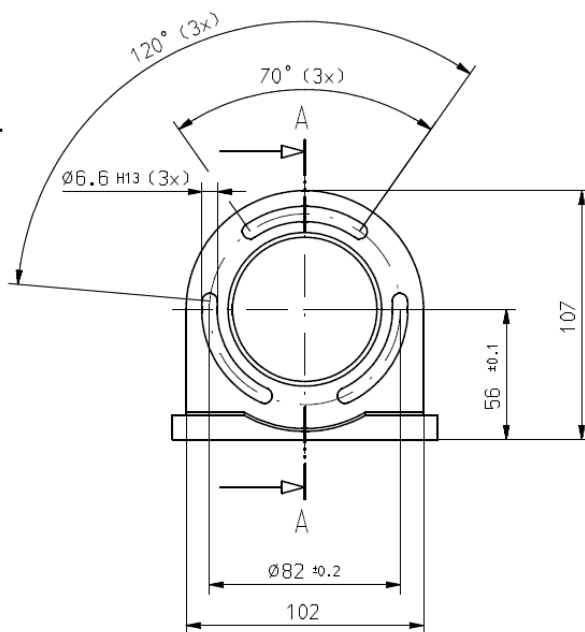

### 2.6.3 Wiring of RTA 602

Wire	Type	Signal	Remark
Pink	I in (+ mA)	Current in/out	Min. 7.5 V to max. 35 V <sub>dc</sub> at 4 to 20 mA (Max. range 3.8 to 20.2 mA)
Brown	I out (- mA)		
Green	S1 (Set 1)	Setup	See the RTA 602 quick guide for setup details Normal operation: <b>All</b> three setup wires must be connected together
Yellow	S2 (Set 2)		
Grey	SC (Set Common)		
White	Not used	Not used	This wire is cut off



### 3. Ordering information

#### 3.1 Available variants

Type	Variant no.	Description	Item no.	Note
RTA 602 w/M	01	Rudder/azimuth Transmitter Analogue with 90 deg. mounting bracket	2951860010-01	Mechanically compatible with RT-2 w/bracket
RTA 602	02	Rudder/azimuth Transmitter Analogue without mounting bracket	2951860010-02	Mechanically compatible with RT-2

#### 3.2 Available accessories

Item no.	Variant no.	Description	Note
1124410003	01	Adjustable lever max. 1127 mm for RTA 602, RTC 600 or RT-2	
1124410004	02	Position linkage 317 mm for RTA 602, RTC 600 or RT-2	
1220000010	03	90 deg. mounting bracket for RTA 602 or RTC 600	Included in RTA 602 variant 01

## 3.3 Order specifications and disclaimer

### 3.3.1 Order specifications

#### Variants

Mandatory information			Additional options to the standard variant		
Item no.	Type	Variant no.	Option	Option	Option

Example:

Mandatory information			Additional options to the standard variant		
Item no.	Type	Variant no.	Option	Option	Option
2951860010-01	RTA 602 w/M	01	None		

#### Accessories

Mandatory information		
Item no.	Variant no.	Accessory

Example:

Mandatory information		
Item no.	Variant no.	Accessory
1124410003	01	Adjustable lever max. 1127 mm for RTA 602, RTC 600 or RT-2

### 3.3.2 Disclaimer

DEIF A/S reserves the right to change any of the contents of this document without prior notice.

The English version of this document always contains the most recent and up-to-date information about the product. DEIF does not take responsibility for the accuracy of translations, and translations might not be updated at the same time as the English document. If there is a discrepancy, the English version prevails.