

N° :

Date : 13 juin 2017

Induction motor

4P LSES 80LG 0,75kW IFT/IE3 B5 230D/380Y/400Y/415Y-460Y 50-60Hz -

Utilisation : Environment Current ; Ambiance Non corrosive ; Finition - ; Zone Non specific ; General applications ; Ambient temperature -16 +40 °C ; Maximum altitude 1000 m.



Motor characteristics : Aluminium alloy housing ; Cast iron DE endshield ; Aluminium alloy NDE endshield.

Motor definition

		Application	General applications
Protection type	-	Main voltage (V)	400
Generation code	IFT	Connection	DY
Efficiency class	IE3	Motor winding (V)	230D/380Y/400Y/415Y-460Y
Number of network phases	3	Rated Frequency (Hz)	50-60
Number of speed	1V	Operation position	IM3001(IMB5)
Polarity	4P	Index of protection	IP55
Motor serie	LSES	Index of cooling	IC411
Frame size (mm)	80	Insulation class	F
Lenght code	LG	Finish	-
HS rated power (kW)	0.750	Moment of inertia J (kg.m ²)	0.0033500
LS rated power (kW)	-	Motor weight (kg)	13.6
Rated speed (min-1)	1450		
Maximum mechanical speed (min-1)	11700		

Common definitions

Paint shade	RAL6000
Paint system	1a (1 polyurethane coat 20/30 microns)

Motor mechanical interface

Mounting flange	FF165	Shaft material type	Steel shaft
Drive end shaft type	IEC STANDARD shaft end	Nuance of shaft material	-
Diameter DE shaft (mm)	19j6	Second shaft extension	-
Length DE shaft (mm)	40	Diameter NDE shaft (mm)	-
DE bearing mounting	Locked	Second shaft end length (mm)	-
DE bearing type	DE ball bearing	NDE bearing type	NDE ball bearing
DE bearing	6205	NDE bearing	6204
Code Type de graissage	Vie		

Motor electrical interface

Connection network type	Terminal box	Cable type	-
Connection network material	Composite materials	Cable gland material	Cable gland not supplied, holes tapped with polyamide plugs
Connection network position	A	Main cable gland type	1xM20 ; With plugs
Connection network orientation	up	Principal cable gland position	Right (1)
Connection network relative position	0		

N° :

Date : 13 juin 2017

Induction motor - 4P LSES 80LG 0,75kW IFT/IE3 B5 230D/380Y/400Y/415Y-460Y 50-60Hz -

Motor options

Vibration level	A (25µm ; 1.6mm/s ; 2.5m/s ²)	Cover	Plastic cover
Balancing type	Half-key (H)	Drip proof cover option	-
Impregnation type	< 95% ; -16+40°C (T)	cooling type	-
Winding thermal protection	-	Forced ventilation characteristics	-
Space heater	-	Encoder type	-
Draining plugs position	6H	Encoder characteristics	-
Nameplate material	Aluminium nameplate	Screw material	Steel screw
Endshield thermal protection	-	Adaptation for vibration sensor	-
Reinforced winding insulation	-		

Motor characteristics (on mains supply)

Main voltage (V)	Rated Frequency (Hz)	HS rated power (kW)	Rated torque (N.m)	Rated speed (min-1)	Rated current (A)	Power factor at 4/4 of the load	Power factor at 3/4 of the load	Power factor at 2/4 of the load	Efficiency at 4/4 (IEC 60 034-2-1) of the load (%)	Efficiency at 3/4 (IEC 60 034-2-1) of the load (%)	Efficiency at 2/4 (IEC 60 034-2-1) of the load (%)
380	50	0.750	4,95	1440.00	1.65	0.82			82.60		
400	50	0.750	4,95	1450	1.65	0,8	0,72	0,59	83.20	83.93	82.61
415	50	0.750	4,95	1452.00	1.60	0.78			83.29		
460	60	-	-	1758.00	1.45	0.76			85.10		

Motor characteristics (on mains supply) 400 V 50 Hz

Starting torque (N.m)	10.89	Id / In	6.2
Average starting torque (N.m)		Id	10.23
Maximum torque (N.m)	14,6	Maximum current (A)	
Unload maximum starting frequency (d/h)	-	No-load current (A)	0.00
Rotor locked time (cold) (s)		Acoustic pressure level (dB(A))	48

Motor characteristics (supplied via drives)

Main voltage (V)	Nominal frequency (Hz)	Temperature rise	Pn (kW)	Nn (min-1)	In (A)	Cos Phi	Mn @ f/10 (N.m)	Mn @ f/5 (N.m)	Mn @ f/3 (N.m)	Mn @ f/2 (N.m)	Mn (N.m)	Mn @ fx1.7 (N.m)	Mn @ fx2 (N.m)
400 Y	50	80K	0.75	1450	1.7	0.8	0.00	4.46	4.95	4.95	4.950	2.84	0.00
400 D	87	80K	1.31	2511	2.96	0.8	0.00	4.46	4.95	4.95	4.950	0.00	0.00

N° :

Date : 13 juin 2017

Induction motor - 4P LSES 80LG 0,75kW IFT/IE3 B5 230D/380Y/400Y/415Y-460Y 50-60Hz -

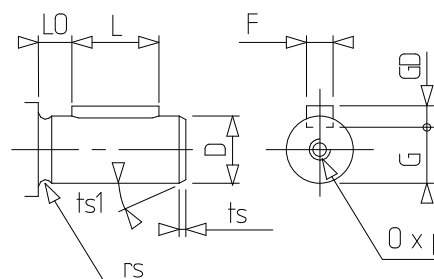
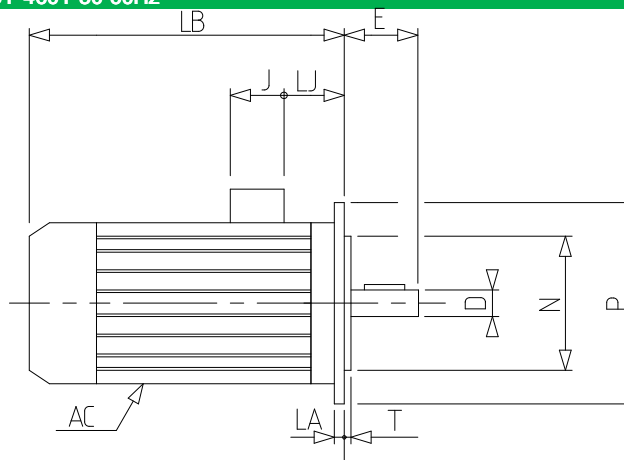
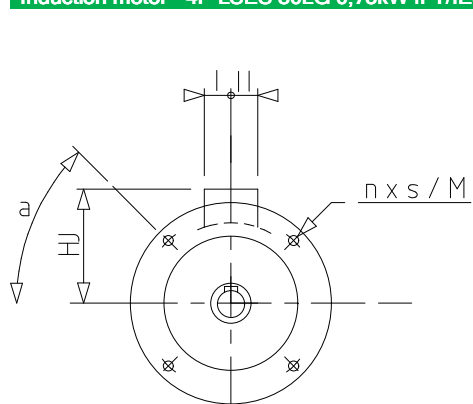

a	45
AC	189.00
D	19j6
E	40
F	6
G	15.5
GD	6
HJ	135.0
I	43
II	43
J	86
L	30
LA	10
LB	267.0
LJ	46.0
LO	6
M	165
N	130
n	4
O	M6
P	200
p	16
rs	0.5
S	12
T	3.5
ts	2
ts1	20