

BRONZE GLOBE VALVE PN16



Size : DN 1/4" to 2"
Ends : Female - Female BSP
Min Temperature : - 10°C
Max Temperature : + 110°C
Max Pressure : 16 Bars
Specifications : Rising rotating stem and handwheel
PTFE packing
PTFE or brass disc

Materials : Bronze body

BRONZE GLOBE VALVE PN16

SPECIFICATIONS :

- Respect the flow direction (indicated by the arrow)
- Rising rotating stem and handwheel
- PTFE packing
- Bronze body
- PTFE or brass disc
- Threaded female BSP cylindrical

USE :

- For common fluids of 2nd group
- Min and max Temperature Ts : - 10°C to + 110°C
- Max pressure Ps : 16 bars (see graph)
- **Do not use for steam**

PRESSURE / TEMPERATURE GRAPH (STEAM EXCLUDED) :

PRESSURE

Bar

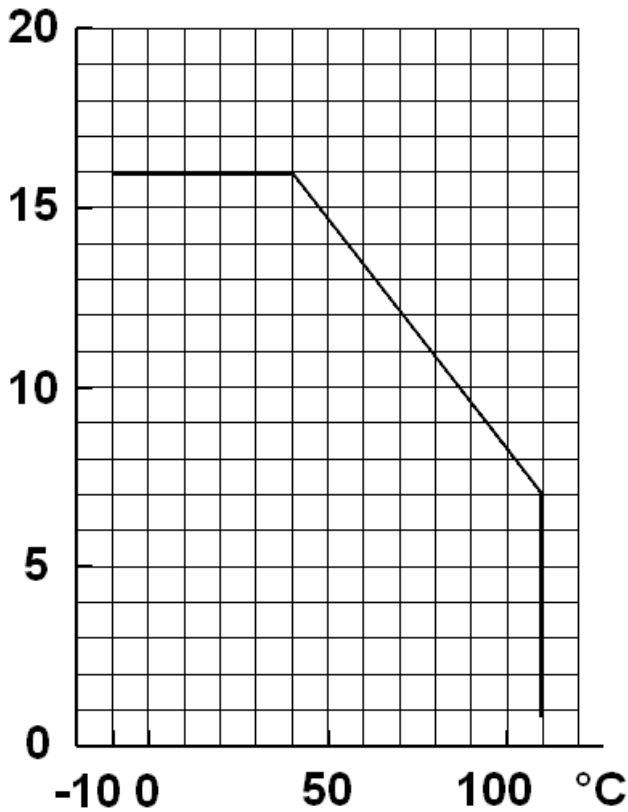

TEMPERATURE

BRONZE GLOBE VALVE PN16

HEAD LOSS GRAPH:

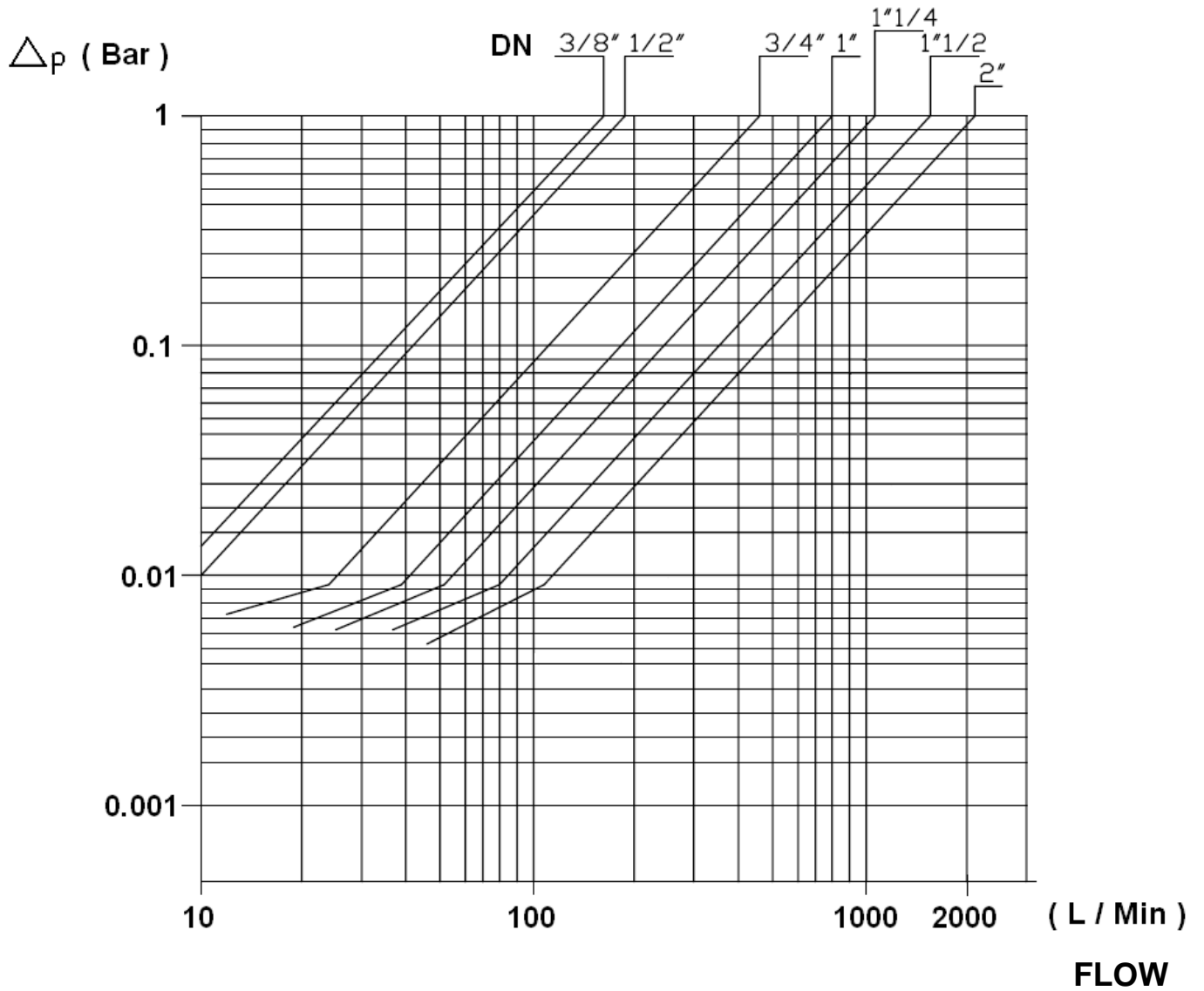

RANGE:

- Bronze body and brass disc, female threaded cylindrical BSP from DN 1/4" to DN 2" **Ref. 460**
- Bronze body and PTFE disc, female threaded cylindrical BSP from DN 1/4" to DN 2" **Ref. 462**

BRONZE GLOBE VALVE PN16

MATERIALS FOR TYPE 460 BRASS DISC :

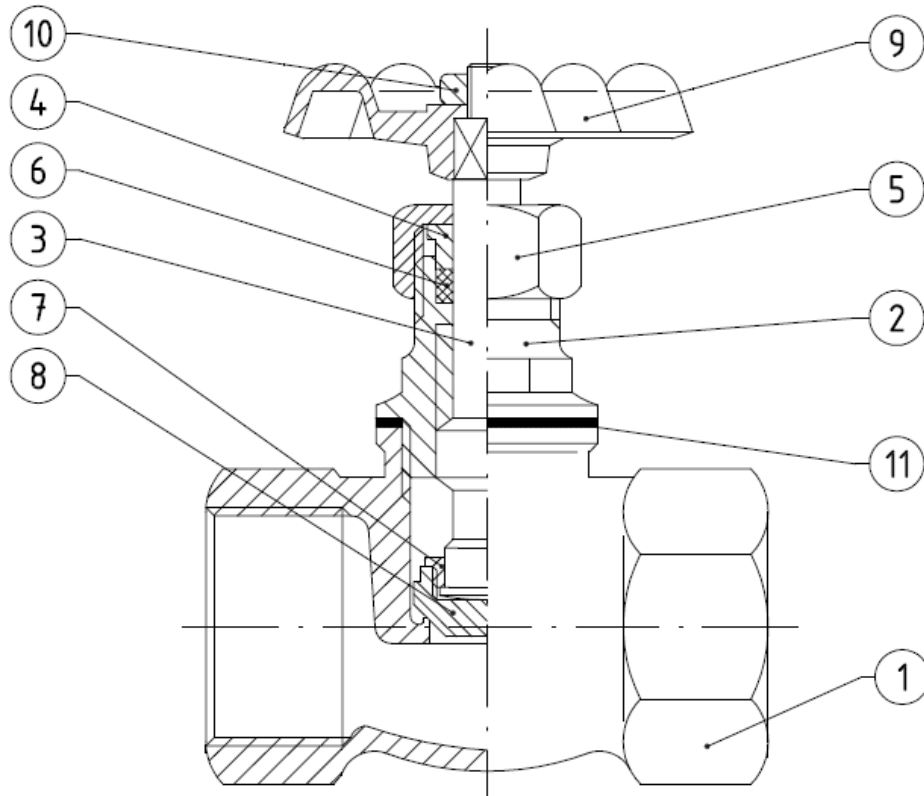

| Item | Designation | Materials 460 |
|------|---------------------------------|-------------------------------------|
| 1 | Body | Bronze C83600 ASTM B62 |
| 2 | Bonnet | Brass CW 617N according to EN 12165 |
| 3 | Stem | Brass CW 614N according to EN 12164 |
| 4 | Gland packing | Brass CW 614N according to EN 12164 |
| 5 | Packing nut | Brass CW 614N according to EN 12164 |
| 6 | Packing | PTFE |
| 7 | Ring | Brass CW 614N according to EN 12164 |
| 8 | Disc | Brass CW 614N according to EN 12164 |
| 9 | Handwheel | Aluminium GD12FE UNI EN 1706 |
| 10 | Handwheel nut | Steel 6S UNI 5589 |
| 11 | Bonnet gasket (DN 1/4" to 1") | Red fiber |

BRONZE GLOBE VALVE PN16

MATERIALS FOR TYPE 462 PTFE DISC :

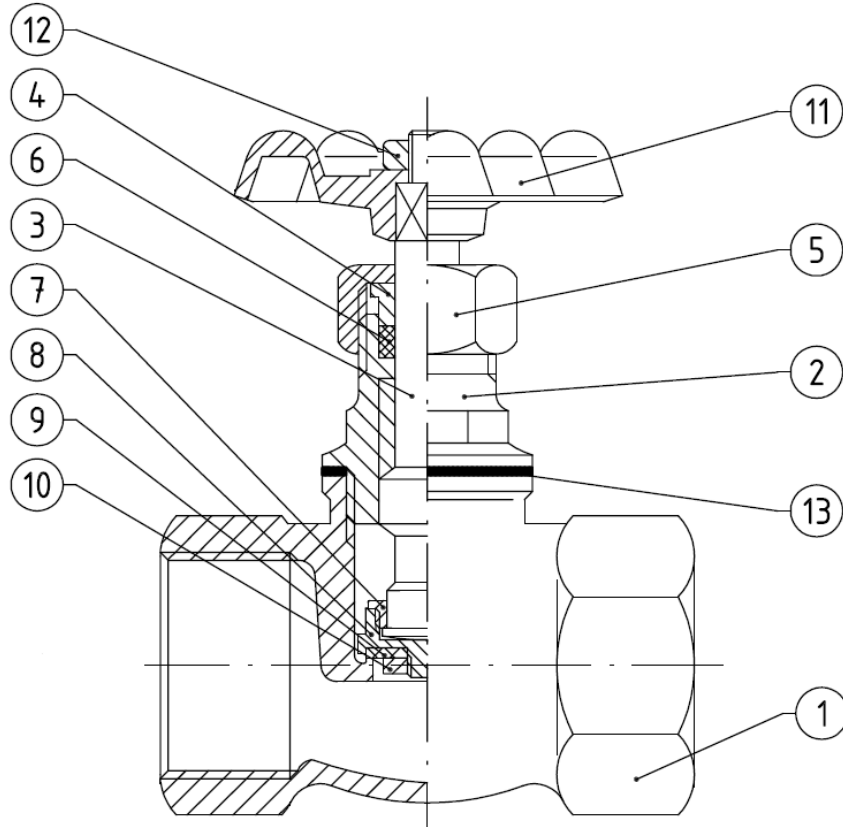

| Item | Designation | Materials 462 |
|------|---------------------------------|-------------------------------------|
| 1 | Body | Bronze C83600 ASTM B62 |
| 2 | Bonnet | Brass CW 617N according to EN 12165 |
| 3 | Stem | Brass CW 614N according to EN 12164 |
| 4 | Packing gland | Brass CW 614N according to EN 12164 |
| 5 | Packing nut | Brass CW 614N according to EN 12164 |
| 6 | Packing | PTFE |
| 7 | Ring | Brass CW 614N according to EN 12164 |
| 8 | Disc | Brass CW 614N according to EN 12164 |
| 9 | Disc ring | PTFE |
| 10 | Disc nut | Brass CW 614N according to EN 12164 |
| 11 | Handwheel | Aluminium GD12FE UNI EN1706 |
| 12 | Handwheel nut | Steel 6S UNI 5589 |
| 13 | Bonnet gasket (DN 1/4" au 1") | Red Fiber |

BRONZE GLOBE VALVE PN16

SIZE REF. 460 BRASS DISC (in mm) :

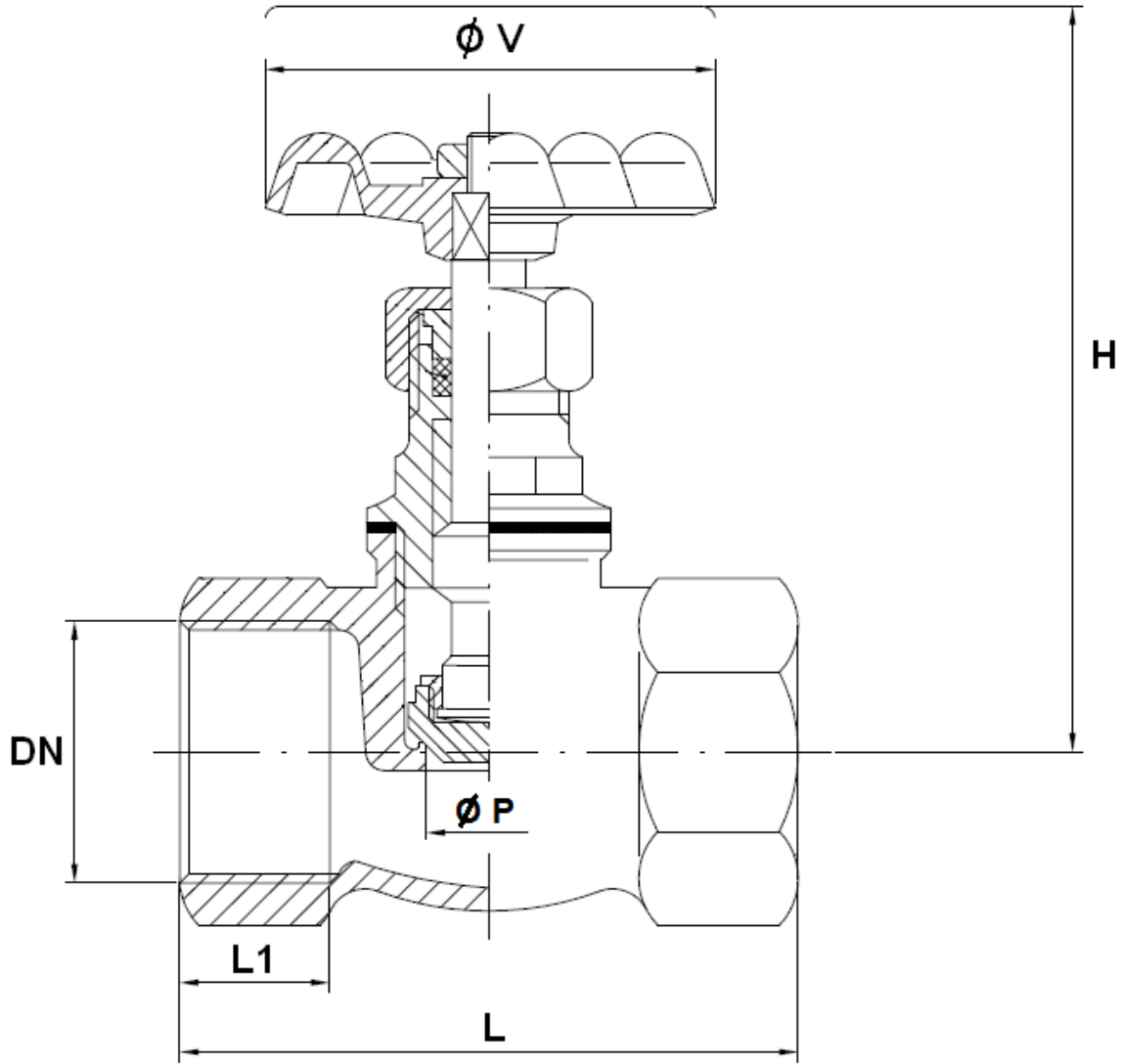

| Ref. | DN | 1/4" | 3/8" | 1/2" | 3/4" | 1" | 1"1/4 | 1"1/2 | 2" |
|------|---------------|------|------|------|------|------|-------|-------|------|
| 460 | L | 45 | 45 | 49 | 55 | 63 | 72 | 89 | 100 |
| | L1 | 9.5 | 9.5 | 11 | 13 | 12 | 15 | 15 | 19 |
| | H (opened) | 66 | 66 | 67 | 78 | 90 | 100 | 115 | 145 |
| | Ø P | 11.5 | 11.5 | 11.5 | 13.5 | 17.5 | 21 | 28.5 | 36 |
| | Ø V | 50 | 50 | 50 | 50 | 55 | 60 | 70 | 80 |
| | Weight (Kg) | 0.2 | 0.2 | 0.21 | 0.32 | 0.46 | 0.68 | 1.03 | 1.45 |

BRONZE GLOBE VALVE PN16

SIZE REF. 462 PTFE DISC (in mm) :

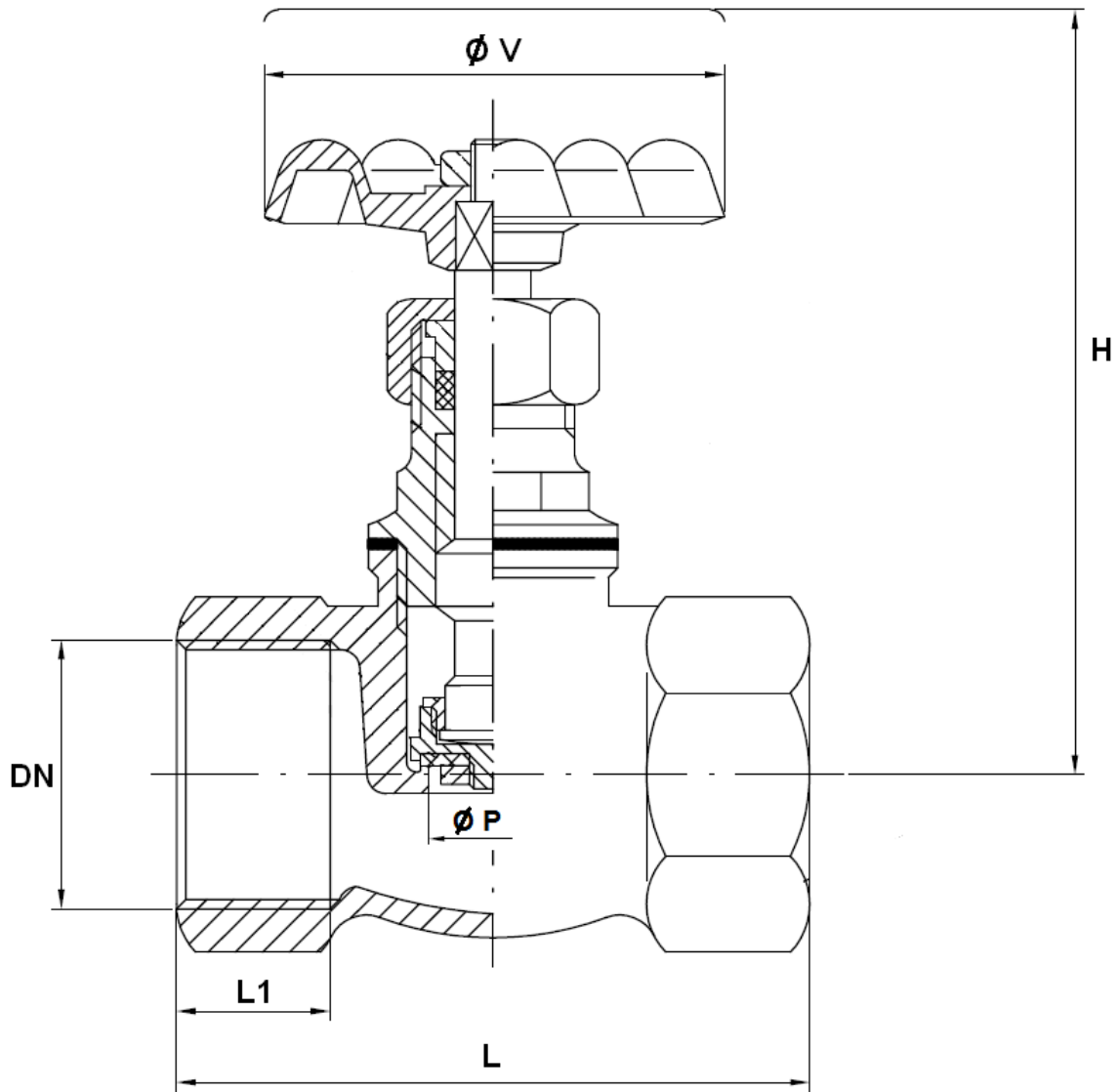

| Ref. | DN | 1/4" | 3/8" | 1/2" | 3/4" | 1" | 1"1/4 | 1"1/2 | 2" |
|------|---------------|------|------|------|------|------|-------|-------|------|
| 462 | L | 45 | 45 | 49 | 55 | 63 | 72 | 89 | 100 |
| | L1 | 9.5 | 9.5 | 11 | 13 | 12 | 15 | 15 | 19 |
| | H (opened) | 66 | 66 | 67 | 78 | 90 | 100 | 115 | 145 |
| | Ø P | 11.5 | 11.5 | 11.5 | 13.5 | 17.5 | 21 | 28.5 | 36 |
| | Ø V | 50 | 50 | 50 | 50 | 55 | 60 | 70 | 80 |
| | Weight (Kg) | 0.2 | 0.2 | 0.21 | 0.32 | 0.46 | 0.68 | 1.03 | 1.45 |

BRONZE GLOBE VALVE PN16

STANDARDS:

- Fabrication according to ISO 9001 : 2015 and ISO 14001 : 2015
- DIRECTIVE 2014/68/EU : CE N° 0497
Risk Category III Module H
- Pressure tests according to EN 12266-1, Rate A
- Threaded female BSP cylindrical according to ISO 228-1

BRONZE GLOBE VALVE PN16

INSTALLATION INSTRUCTIONS

GENERAL GUIDELINES :

- Ensure that the valves to be used are appropriate for the conditions of the installation (type of fluid, pressure and temperature).
- Be sure to have enough valves to be able to isolate the sections of piping as well as the appropriate equipment for maintenance and repair.
- Ensure that the valves to be installed are of correct strength to be able to support the capacity of their usage.
- **Installation of all circuits should ensure that their function can be automatically tested on a regular basis (at least two times a year).**

INSTALLATION INSTRUCTIONS :

- **Before installing the valves, clean and remove any objects from the pipes** (in particular bits of sealing and metal) which could obstruct and block the valves.
- **Ensure that both connecting pipes either side of the valve (upstream and downstream) are aligned (if they're not, the valves may not work correctly).**
- **Make sure that the two sections of the pipe (upstream and downstream) match, the valve unit will not absorb any gaps. Any distortions in the pipes may affect the tightness of the connection, the working of the valve and can even cause a rupture.** To be sure, place the kit in position to ensure the assembling will work.
- The theoretical lengths given by ISO/R7 for the tapping are typically longer than required, the length of the thread should be limited, and **check that the end of the tube does not press right up to the head of the thread.**
- **Never use a vice to tighten the fixings of the valve.**
- **If sections of piping do not have their final support in place, they should be temporarily fixed. This is to avoid unnecessary strain on the valve.**
- **It may be necessary to screw the packing gland during using according to the type of use.**
- **Do not use a tool to shut the valve**
- **Fluids in the valve must not contain solid objects (it could damaged the seat).**
- It's recommended to operate the valve (open and close) 1 to 2 times per year