

# USB502 detector base series

Universal base for SecuriStar fire detectors



Fig. 1 USB 502 detector base series

## Description

The USB 502 detector base series is used for connecting and mounting the SecuriStar detector family and is completely compatible with the USB 501 detector base series, although this series has a larger connection compartment inside the base. A 6-pin terminal block is present in the interior of the USB 502 for connecting the base to the fire detectors. If necessary, an additional 4-pin terminal block can be fit-tered in the corresponding snap-in holder to create support points. The detector is fixed in the USB 502 by means of a bayo-net connection. The base is provided with elastic inserts for entry of the in-installation cables.

## USB 502 variants

Variant	Properties, application
USB 502-1	Standard base, surface mounting, with loop contact (green terminal)
USB 502-2	Base for false ceilings, flush mounting, with loop contact (green terminal)
USB 502-3	Base for wet rooms, surface mounting, with loop contact (green terminal)
USB 502-4	Base for mounting in concrete, flush mounting, with loop contact (green terminal)
USB 502-5	Base for raised floors with pipe clamp, with loop contact (green terminal)
USB 502-6	Standard base, surface mounting, without loop contact (black terminal)
USB 502-7 Ex-i	Base for Ex zones with cable screw union, without loop contact (black terminal)
USB 502-8 Ex-i	Standard base for Ex zones, surface mounting, without loop contact (black terminal)
USB 502-20	Base with illuminated ring, surface mounting, without loop contact (black terminal)

## Loop contact

The USB 502-1 to 502-5 base variants (green terminal block) are equipped with a loop contact. This means terminals 2 and 3 are connected and are opened automatically when the detector is inserted. On the 573 and MMD detector series, the connection (and thus also the ring) is closed again when the detector is removed. On the 563 detector series, the connection remains open and the control panel signals a fault. The USB 502-6, USB 502-7 Ex-i, USB 502-8 Ex-i and USB 502-20 base variants have no loop contact (black terminal block). Terminals 2 and 3 are not connected and the connection remains open when the detector is removed.

## Planning



The country-specific guidelines for planning and installing automatic fire detection and fire alarm systems apply when planning.

A tool is available for calculating the maximum possible loop length and the maximum number of participants.

An optical light-guide bar is integrated in the shadow gap area on the USB 502-20, which allows for an extra optical display in addition to the alarm LED on the attached detector. The LED flashes red in the event of an alarm and is visible from all sides (360°). The triggering and power supply are made via the alarm output of the detector. The alarm output of the detector can also be triggered by an alarm on another detector in the same SecuriFire SCP. The parameters are assigned via SecuriFire Studio. The maximum number of optical displays triggered at the same time in the USB 502-20 base depends on the total number of connected detectors and modules, the line length and the wire cross-section on the addressable loop.

The USB 502-20 base is supported as of SecuriFire Studio R2.0. The USB 502-20 does **not** comply to EN 54-23!

## Application overview for detector type and base variants

Detector type	Detector category	USB 502 variant		
		-1/-2/-3/-4/-5/-6	-7 Ex-i/ -8 Ex-i	-20
SSD531, UTD531, STD531, SCD573, TCD573, MCD573, MCD573X, CCD573X, MCD573X-S, MCD573X-SCT, MCD573X-SP, MCD573X-SPCT	Addressable loop	✓	✗	✓
MMD140, MMD150	Modernisation	✓	✗	✗
SSD521, UTD521, SCD563, TCD563	Collective line	✓	✗	✗
MMD130 Ex-i	Ex-i detector	✗	✓	✗

## Mounting / installation

The USB 502 base must be permanently mounted by means of two screws (flat or oval-head screws  $\varnothing$  3.5 to 4 mm / min. head diameter 6.9 mm) to withstand movement due to pressure, tension and torsion.

For this purpose, the elastic insert **A** (slots) in the bottom of the base should be broken through. Depending on the type of cable entry, the installation cables may have to be pulled through the openings **B** in the bottom of the base before the base is fastened.

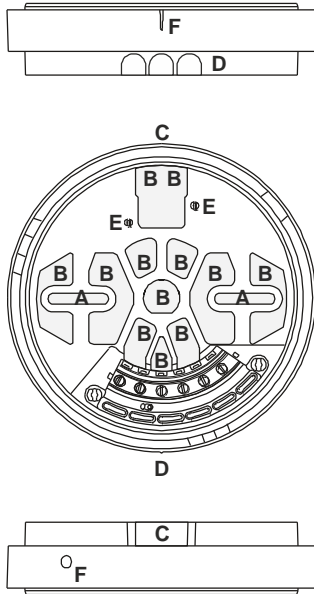

Fig. 2 Mounting aids

- A** Elastic insert for fastening the base
- B** Elastic insert for cable entry, flush mounting
- C+D** Insert on the inner circumference (not for USB 502-20)  
Cable entry from direction "C" not possible with an auxiliary terminal fitted.
- E** Fastening for auxiliary terminals (not for USB 502-20)
- F** Marking for LED adjustment and the correct stop position with inserted detector
- G** A screw can be inserted in the pre-punched indent on the outside of the base for securing the inserted detector against removal.

Depending on the location of the cable entry, break through the corresponding insert. The installation cable must enter in such a way that neither dust nor moisture can penetrate into the base.

If a risk of water penetrating the base through the supply line is anticipated, then the cable must be fitted with a drip nose before it reaches the base. This applies in particular to flush mounting installations in wet rooms (garages etc.). In such applications, the bases must be mounted next to the flush mounting concrete box and openings **C** or **D** must be used for inserting the cable (see Fig. 4). The base has no strain relief. The cable entry can be made either from the rear through the bottom of the base (opening **B**) or from the side on the inner circumference (opening **C** or **D**) (see Figs. 2, 3 and 4).

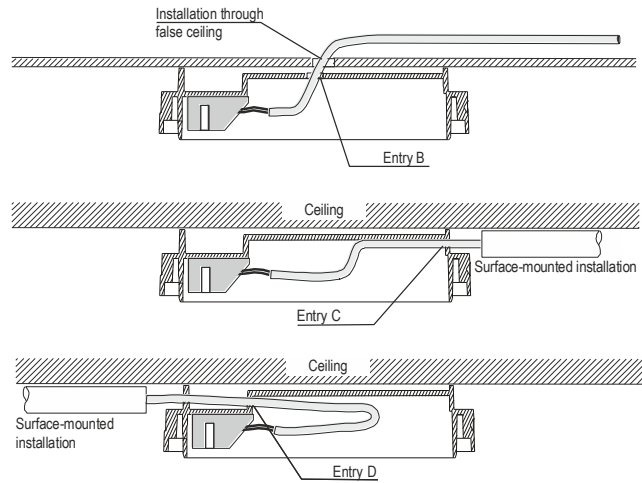

Fig. 3 Cable entry

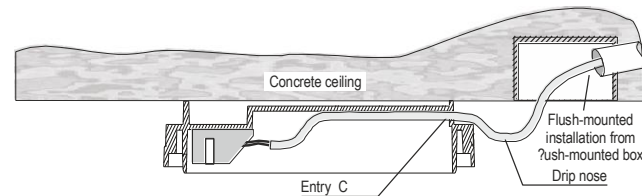

Fig. 4 Cable entry in wet rooms

With surface mounting, the base must be fastened on a smooth, clean surface. To prevent the base from deforming, there must be no unevenness on the surface when fastening to concrete ceilings.

The bases may not be positioned directly above cable ducts, water pipes, etc. A lateral distance of at least 0.5 metres from lamps, walls, ceiling joists, etc. must be maintained.

Since the alarm indicator lamp on the SecuriStar fire detector can be seen around 360°, the exact mounting direction of the base is not important (though LED orientation towards the room or sector entrance is recommended).

When several detectors are mounted in large rooms or corridors, it is recommended to mount all bases in the same direction for visual reasons (e.g. by positioning the fixing holes of all bases parallel to the wall).

### Cable specification

For the electrical installation, cable types with specifications according to the "Application Information SecuriFire-AI04" document must be used.

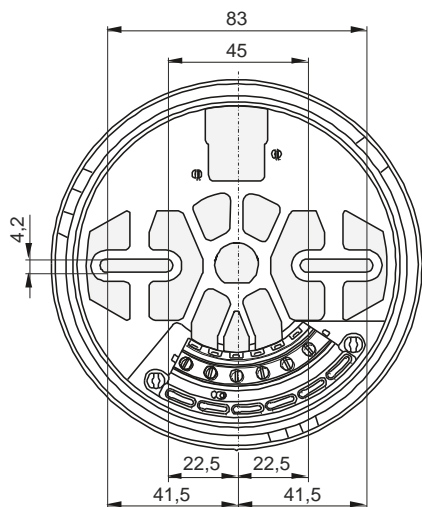

Fig. 5 Dimensioned drawing, slots

### Installation notes for USB 502-2

The USB 502-2 base variant can be installed in any standard-compliant false ceiling and consists of:

- Mounting ring with sleeve and claw fittings
- USB 502-1 standard base
- 158 mm protective ring for covering the sleeve of the mounting ring (a 177 mm ring is also available as an optional accessory for additional coverage)

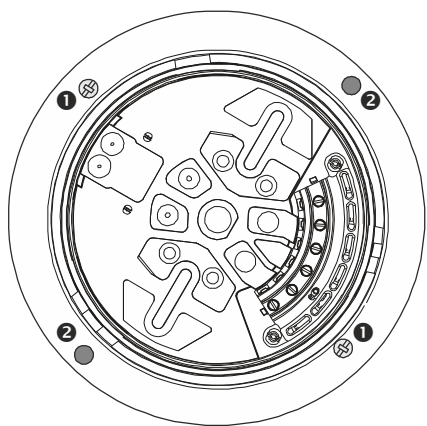

Fig. 6 Plan view of USB 502-2 base with sleeve (false ceiling, flush mounting)

Insert the mounting ring from below in the prepared ceiling cut-out and fasten to the ceiling with the integrated claw fittings ❶ or using two screws ❷ (fastening holes).

Insert the protective ring (covers the screws) afterwards together with the detector.

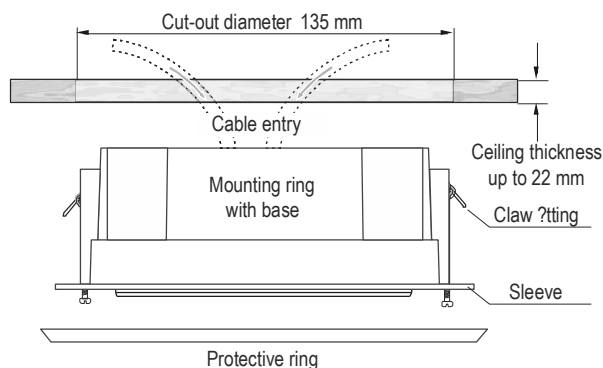

Fig. 6 USB 502-2 installation

### Installation notes for USB 502-3

The USB 502-3 base variant is specially designed for use in wet rooms and consists of:

- Mounting box with four cable inserts PG 13.5 and stopper plugs
- USB 502-1 standard base
- Sealing ring made of cellular rubber

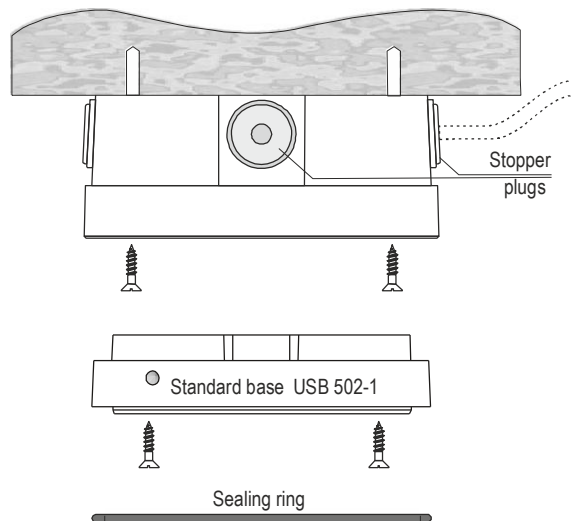

Fig. 6 USB 502-3 installation (wet rooms)

Fasten the mounting box to the ceiling with the two screws. Break through the stopper plugs, insert the cable and screw the standard base onto the box. Insert the sealing ring afterwards together with the detector. If needed, the stopper plugs can be replaced with PG 13.5 cable screw unions.

## Installation notes for USB 502-4

The USB 502-4 base variant is mounted on the formwork and then set in concrete, and consists of:

- Concrete box, mounting ring with sleeve and sealing insert
- USB 502-1 standard base
- 158 mm protective ring for covering the sleeve (a 177 mm ring is also available as an optional accessory for additional coverage)

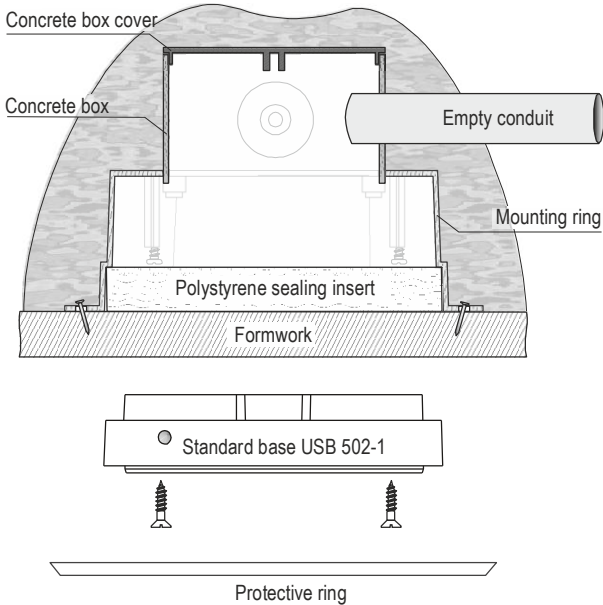

**Fig. 6 USB 502-4 installation (mounting in concrete, flush mounting)**

The installation cable is inserted through the concrete box. Fasten the mounting ring with nails so it is immovable and tightly sealed on the formwork. After the concrete is poured and the box installed, mount the standard base in the mounting ring using the screws provided. Insert the protective ring afterwards together with the detector.

## Installation notes for USB 502-5

The USB 502-5 base variant is installed in cable shafts and raised floors. It is equipped with a pipe clamp that can be used for fastening the base to pipes, struts or similar. The base can be rotated for aligning the detector.

## Installation notes for USB 502-7 Ex-i and USB 502-8 Ex-i

The USB 502-7 Ex-i and USB 502-8 Ex-i base variants are permitted for use in Ex zones in combination with the MMD 130 Ex-i multi-criteria detector.



The MMD 130 Ex-i fire detector may only be operated with the USB 502 / USB502 and using a Z787 / Z787F or GTW 01/02.



The safety barrier and GTW must be installed in the safe area.

The fire detector base is intended for surface mounting. The Ex-i detector is secured in the base with a bayonet connection. Ensure that the sealing ring (O-ring) is used when installing the detector.

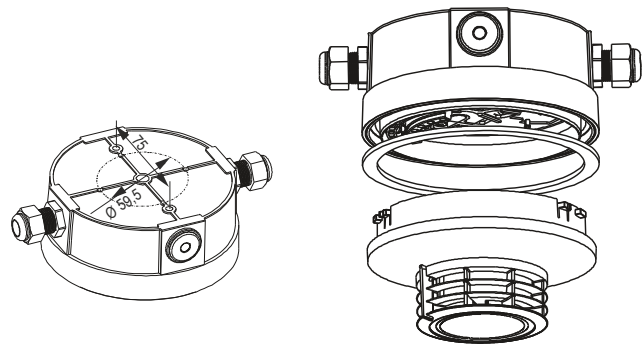

**Fig. 7 USB 502-7 Ex-i installation**

The USB 502-8 Ex-i fire detector base can be used for surface mounting without additional strain relief or cable sealing.

In the last base of a fire detection zone, terminals 3 and 4 must be terminated with a termination resistance. The correct resistance value can be seen in data sheet MMD130Ex-i T811045. The supply line must be connected to terminals 1 and 2.

Branch sockets in an Ex-i installation must meet the following requirements:

- Min. protection class IP 42
- Min. creepage distance of 3 mm between the terminals



The distributor sockets must be equipped with blue cable screw unions for visual identification of the Ex-i circuit.

### Terminal assignment

Terminal	Signal
1	GND line (in and out)
2	Plus line (in or out, data)
3	Plus line (in or out, data)
4	GND alarm output
5	Plus alarm output
6	Support point (screening)



**USB 502-20:**  
The terminals 4 and 5 (alarm output) are used for triggering the illuminated ring. Additional use is not permitted!

The data sheet of the respective detector must be observed during connection.

### Connection examples

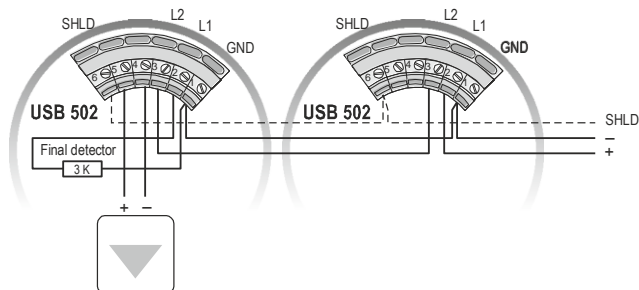

Fig. 8 USB 502 connection with line technology

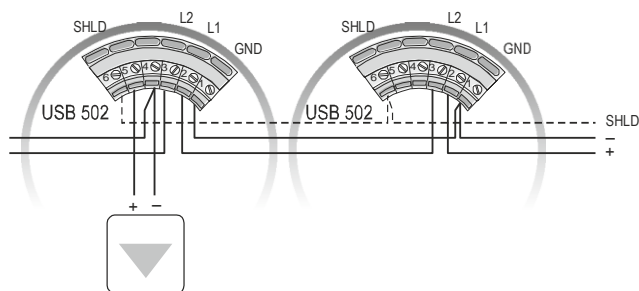

Fig. 9 USB 502 connection with addressable loop technology

### Dimensioned drawings

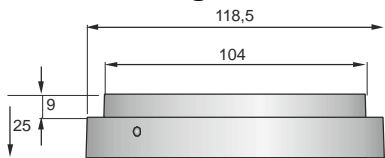

Fig. 10 USB 502-1, USB 502-6, USB 502-8 Ex-i

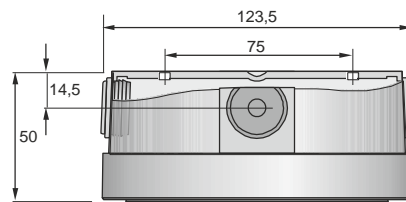

Fig. 12 USB 502-3

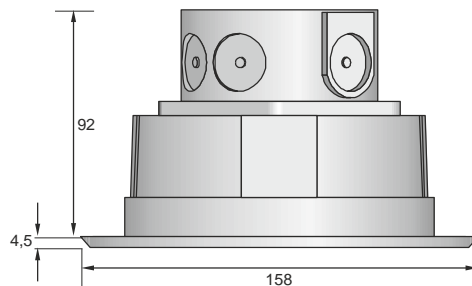

Fig. 13 USB 502-4

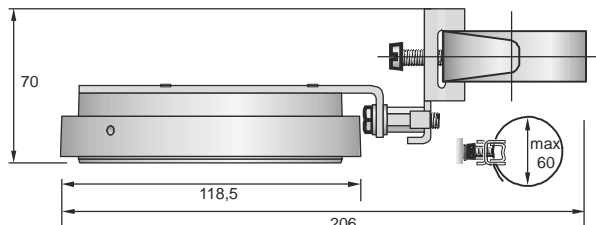

Fig. 14 USB 502-5

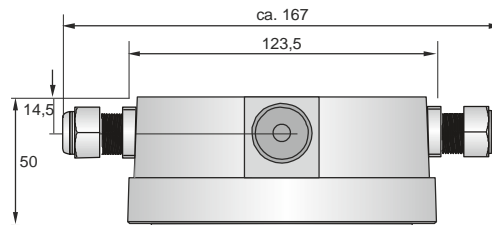

Fig. 15 USB 502-7 Ex-i

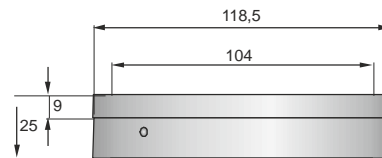

Fig. 16 USB 502-20

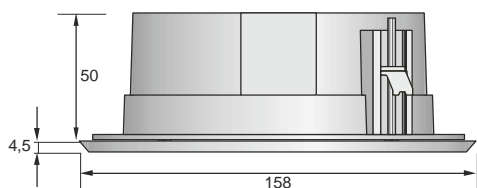

Fig. 11 USB 502-2

# Data sheet

## Article numbers / spare parts

Short designation	Swiss art. no.	Art. no.
USB 502-1 standard base	123.265244	30-4100005-01-01
USB 502-1 MC (multicolour)	123.985295	30-4100005-91-01
USB 502-2 base for false ceilings	123.265246	30-4100005-02-01
USB 502-3 base for wet rooms	123.265248	30-4100005-03-01
USB 502-4 base for mounting in concrete	123.265250	30-4100005-04-01
USB 502-5 base for raised floors	123.265252	30-4100005-05-01
USB 502-6 standard base	123.265254	30-4100005-06-01
USB 502-6 MC (multicolour)	123.985297	30-4100005-96-01
USB 502-7 Ex-i base for Ex zones	123.265256	30-4100005-07-01
USB 502-8 Ex-i standard base for Ex zones	123.265301	30-4100005-08-01
USB 502-20 standard base with illuminated ring	123.249467	20-2100019-01-01
USB 502 support point terminal	322.265240	31-3100002-01-01
177 mm protective ring	123.231835	3110470
158 mm protective ring MC (multicolour)	988.943584	3110464
DNP 502 (detector number plate)	322.265242	31-3100001-01-01
DNP 521/531 detector number plate (optional)	322.215880	3110320
Replacement sealing ring for USB 502-3	---	3210296

## Technical data

Power consumption (only USB 502-20)	Typically 0.9 mA
Illuminated ring (only USB 502-20)	
Colour	Red (on alarm transmission)
Visibility	360°
Flashing frequency	1.2 to 3 Hz
Light intensity	approx. 1 cd
Area of application	Dry and wet rooms (see section "Mounting / installation")
Protection type (with inserted detector)	See detector data sheet
Ambient temperature	-25 ... +70 °C USB 502-20: -25 ... +60 °C
Ambient humidity (continuous, without condensation) when ≤ 34 °C	10 ... 95 % rel. humidity
Ambient humidity (continuous, without condensation) when > 34 °C	max. 35 g/m <sup>3</sup> min. 10 % rel. humidity
Installation type (depending on variant)	Surface mounting/flush mounting
Dimensions	See dimensioned drawing
Housing material	PC-ABS, TPE
Housing colour	Electric white (similar to RAL 9003)
Connection	Screw terminals, max. 2.5 mm <sup>2</sup>
Weight (gross, including packaging)	
USB 502-1, USB 502-6 and USB 502-8 Ex-i	approx. 90 g
USB 502-2	approx. 210 g
USB 502-3	approx. 189 g
USB 502-4	approx. 179 g
USB 502-5	approx. 229 g
USB 502-7 Ex-i	approx. 200 g
USB 502-20	approx. 100 g
VdS approval	Included with detectors (except USB 502-5, -7 Ex-i, -8 Ex-i)