

Xtra Long Life 10 million cycles

USB/Ethernet RF Switch Matrix RC-8SPDT-A18

50Ω DC to 18 GHz

The Big Deal

- 8 mechanical SPDT switch box
- High reliability, 10 million switch cycles
- 20W power rating (cold switching)
- High isolation, 85 dB typ



Case Style: LM1852

Model No.	Description	Qty.
RC-8SPDT-A18	USB/Ethernet RF Switch	1
Included Accessories		
AC/DC-24-3W1	AC/DC 24V Adapter	1
CBL-3W1-XX	AC Power Cord (see Ordering Information)	1
USB-CBL-AB-3+	2.7 ft USB cable	1

Applications

- R&D
- Automated Test equipment
- Controlling RF signal paths

RoHS Compliant

See our web site for RoHS Compliance methodologies and qualifications

Product Overview

Mini-Circuits' RC-8SPDT-A18 is a general purpose RF switch matrix controlled via either USB or Ethernet-TCP/IP (supports HTTP and Telnet protocols). The model contains 8 electromechanical SPDT, absorptive fail-safe RF switch constructed in break-before-make configuration and powered by +24VDC, with switching time of 25 ms typical. The RF switches operate over a wide frequency band from DC to 18 GHz, have low insertion loss (0.2 dB typical) and high isolation (85 dB typical), making the switch matrix perfectly suitable for a wide variety of RF applications.

The RC-8SPDT-A18 is constructed in a compact, rugged metal case (4.5" x 12.0" x 2.25") with 24 SMA (F) connectors (COM,1 and 2 for each switch), USB type B port, standard RJ45 network socket and DC power input. Full software support is provided and can be downloaded from our website any time at <https://www.minicircuits.com/softwaredownload/rfswitchcontroller.html>. The package includes our user-friendly GUI application for Windows and a full API with programming instructions for Windows and Linux environments (both 32-bit and 64-bit systems). Also included is a 2.7 ft USB cable and AC/DC power adapter. Longer USB cables, Ethernet cables and a mounting bracket are available as optional accessories.

Key Features

Feature	Advantages
Ethernet-TCP/IP- HTTP and Telnet Protocols (Supports DHCP and Static IP)	The RC-8SPDT-A18 switch matrix can be controlled from any Windows®, Mac®, or Linux® computer, or even a mobile device with a network connection and Ethernet-TCP/IP (HTTP or Telnet protocols) support. Using a VPN would allow remote control from anywhere in the world.
USB HID (Human Interface Device)	User may also control the switch matrix via USB connection. Plug-and-Play, no driver required. Compatible with Windows® or Linux® operating systems using 32 and 64 bit architecture.
RF SPDT absorptive electromechanical switches	Wideband (DC to 18 GHz) with low insertion loss (0.2 dB typ.), very high isolation (85 dB typ.), and high power rating (20W cold switching).
Switch Cycle Counters	Allows user to monitor the exact usage and plan test requirements accordingly.
Break-before-make configuration	Prevents the momentary connection of the old and new signal paths and reduces transient phenomena.

Trademarks: Windows is a registered trademark of Microsoft Corporation in the United States and other countries. Linux is a registered trademark of Linus Torvalds. Pentium is a registered trademark of Intel Corporation. Mac is a registered trademark of Apple Corporation in the United States and other countries. Neither Mini-Circuits nor the Mini-Circuits RC-8SPDT-A18 are affiliated with or endorsed by the owners of the above referenced trademarks. Mini-Circuits and the Mini-Circuits logo are registered trademarks of Scientific Components Corporation.

Patents: Protected by US Patents 5,272,458; 6,414,577; 6,650,210; 7,633,361 and 7,843,289



www.minicircuits.com P.O. Box 350166, Brooklyn, NY 11235-0003 (718) 934-4500 sales@minicircuits.com

Rev. C
M171384
EDR-10927/10F1
RC-8SPDT-A18
RAV
181206
Page 1 of 17

Electrical Specifications

Parameter	Port	Conditions	Min.	Typ.	Max.	Units
Frequency	All RF Ports	—	DC		18	GHz
Power On Sequence: Connect the 24V power, followed by the USB control and/or Ethernet cable before turning on the Switch Matrix.						
RF Insertion Loss (per switch)		DC to 1 GHz	–	0.10	0.15	dB
		1 GHz to 8 GHz	–	0.15	0.30	
		8 GHz to 12 GHz	–	0.25	0.40	
		12 GHz to 18 GHz	–	0.30	0.50	
RF VSWR		DC to 1 GHz	–	1.05	1.10	:1
		1 GHz to 8 GHz	–	1.20	1.30	
		8 GHz to 12 GHz	–	1.20	1.35	
		12 GHz to 18 GHz	–	1.25	1.40	
RF Isolation (per switch)		DC to 1 GHz	85	100	–	dB
		1 GHz to 8 GHz	75	90	–	
		8 GHz to 12 GHz	70	80	–	
		12 GHz to 18 GHz	60	66	–	
Switching Time		–	–	25	–	ms
RF Power (cold switching) ^{1,2}		–	–	–	20	W
Rated Voltage	24V _{DC} IN	provided via external power adapter	23	24	25	V
	USB Port	–	–	5	–	
Rated Current	24V _{DC} IN	All switches in COM -> 2 position	–	1500	2050	mA
		All switches in COM -> 1 position	–	170	220	
	USB Port	All switches in COM -> 2 position	–	10	20	
		All switches in COM -> 1 position	–	10	20	
Life (per switch)		@ 100 mW (hot switching) ³	10	–	–	million switching cycles
		@ 1 W (hot switching) ³	–	3	–	

¹ Power handling is specified with RF applied to the COM port and external load connected to either 1 or 2 of the respective switch.

² Cold switching describes switch operation where there is no significant user signal present at the moment the switch contacts open or close.

³ Exceeding these limits will result in reduced life.

Absolute Maximum Ratings⁴

Operating Temperature	0°C to 40°C
Storage Temperature	-15°C to 85°C
DC Voltage max.	26V
RF power (through path)	20W
RF power (into internal termination)	1W

⁴ Permanent damage may occur if any of these limits are exceeded.

Connections

24V _{DC} IN	(2.1 mm center positive DC Socket)
RF Switch A (1, COM, 2)	(SMA female)
RF Switch B (1, COM, 2)	(SMA female)
RF Switch C (1, COM, 2)	(SMA female)
RF Switch D (1, COM, 2)	(SMA female)
RF Switch E (1, COM, 2)	(SMA female)
RF Switch F (1, COM, 2)	(SMA female)
RF Switch G (1, COM, 2)	(SMA female)
RF Switch H (1, COM, 2)	(SMA female)
USB	(USB type B receptacle)
Network (Ethernet/LAN)	(RJ45 socket)

Block Diagram

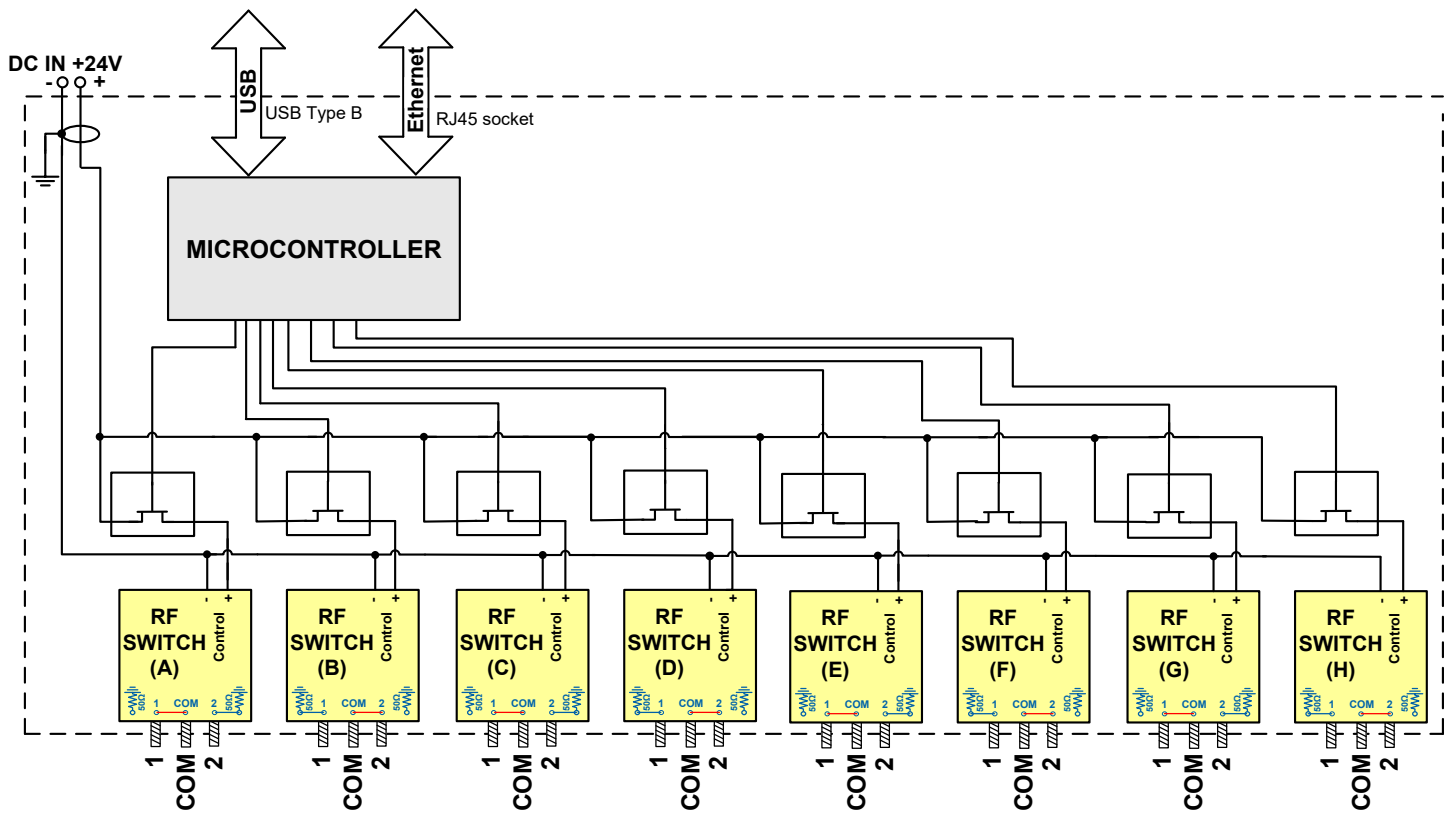

Outline Drawing (LM1852)

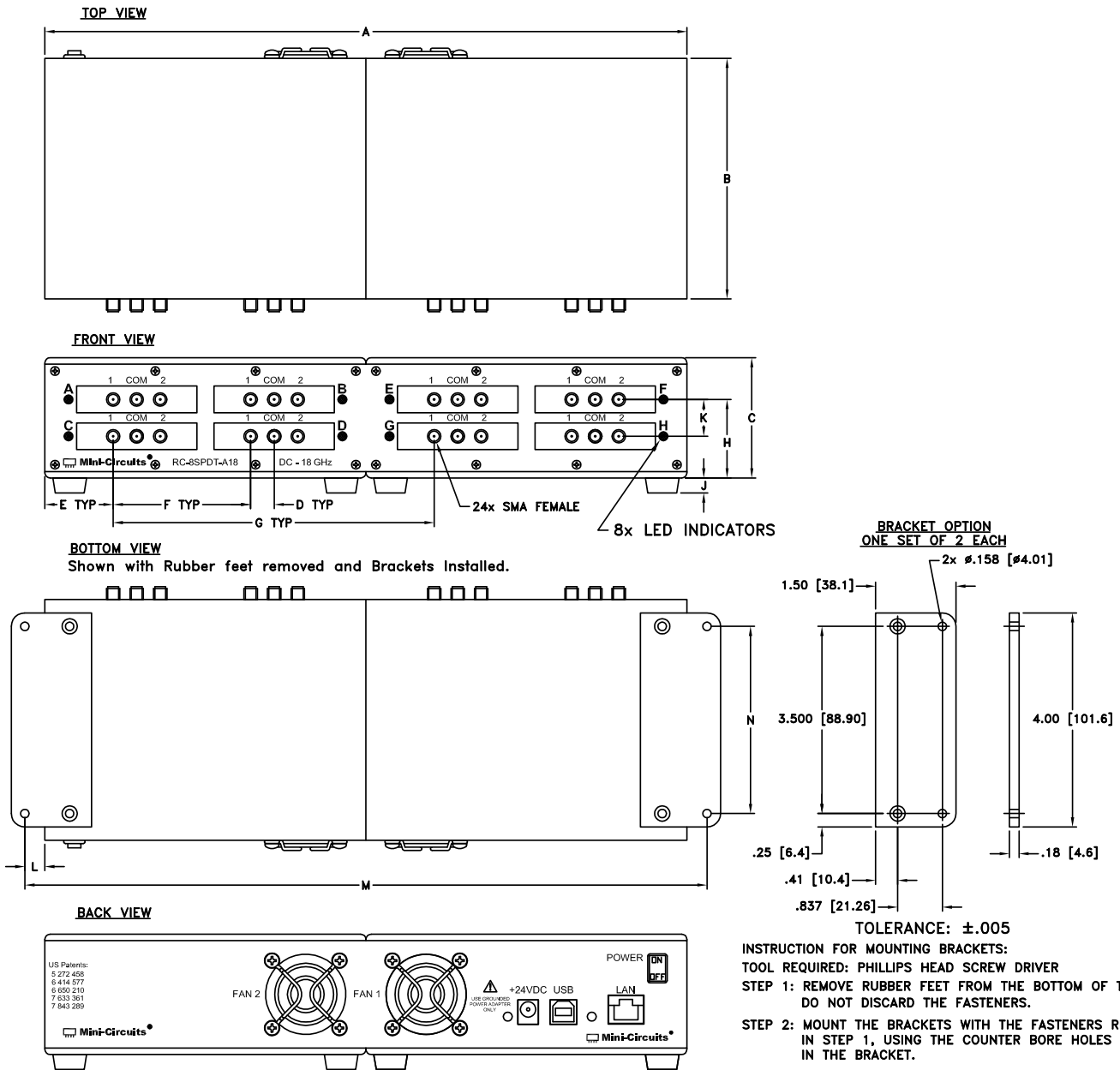

Outline Dimensions (inch/mm)

A	B	C	D	E	F	G	H	J	K	L	M	N	WT. GRAMS
12.00	4.50	2.25	.440	1.28	2.57	6.00	1.47	.28	.688	.375	12.75	3.500	2290
304.8	114.3	57.2	11.18	32.5	65.28	152.4	37.34	7.11	17.5	9.52	323.85	88.9	

Configuration A: 8 SPDT switches

- Power handling is specified with RF applied to the COM port and output load connected to either 1 or 2 of the respective switch.
- When connecting a coaxial semi flex cable, tighten connectors alternately using an 8in/lb torque wrench to insure proper contact at each end.

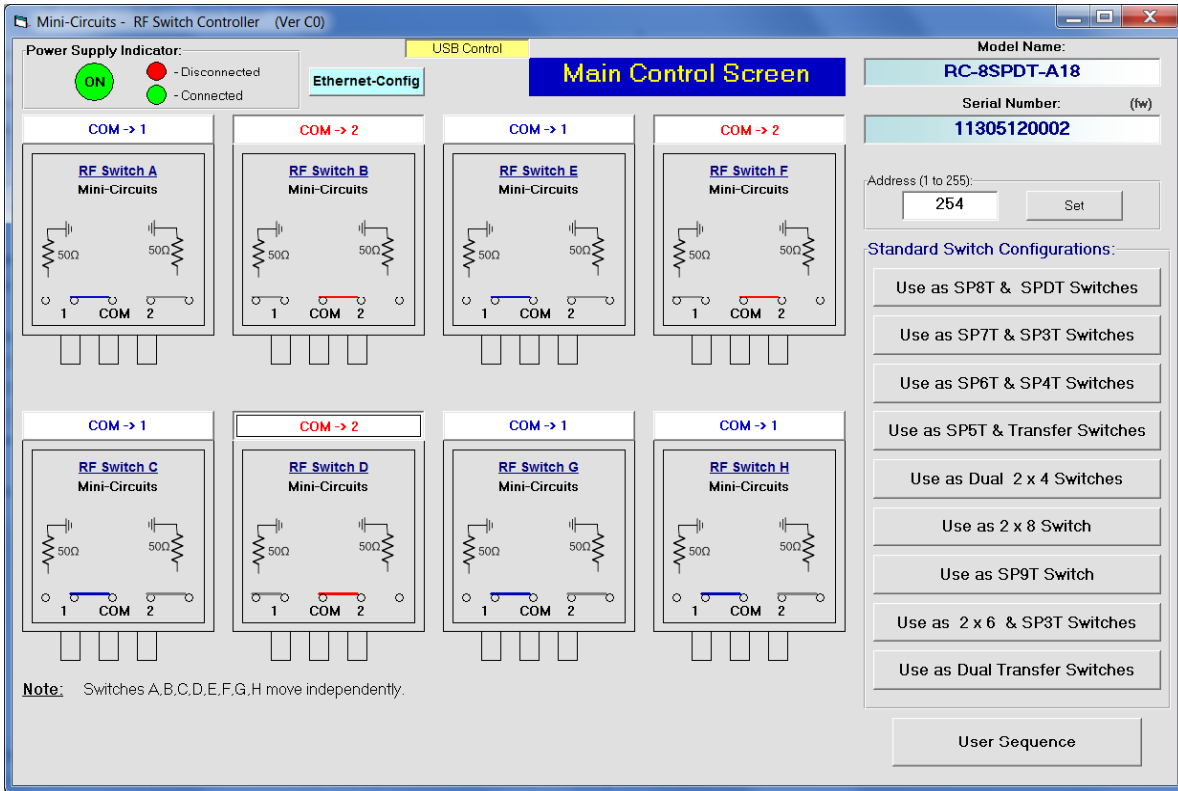

Config. A

SPDT: Any switch Logic

IN \leftrightarrow Out1 : 0

IN \leftrightarrow Out2 : 1

Switches move independently.

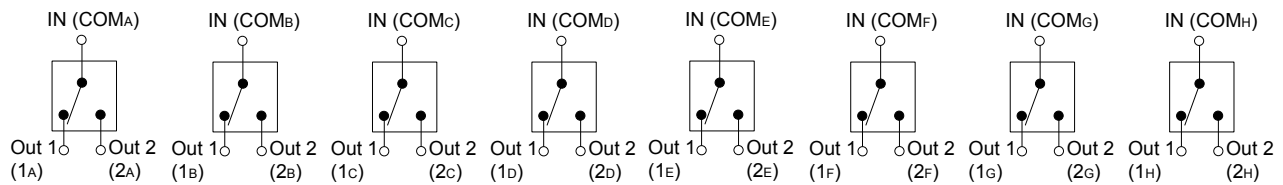

Configuration B: SP8T & SPDT switches

- Power handling is specified with RF applied to the COM port and output load connected to either 1 or 2 of the respective switch.
- When connecting a coaxial semi flex cable, tighten connectors alternately using an 8in/lb torque wrench to insure proper contact at each end.

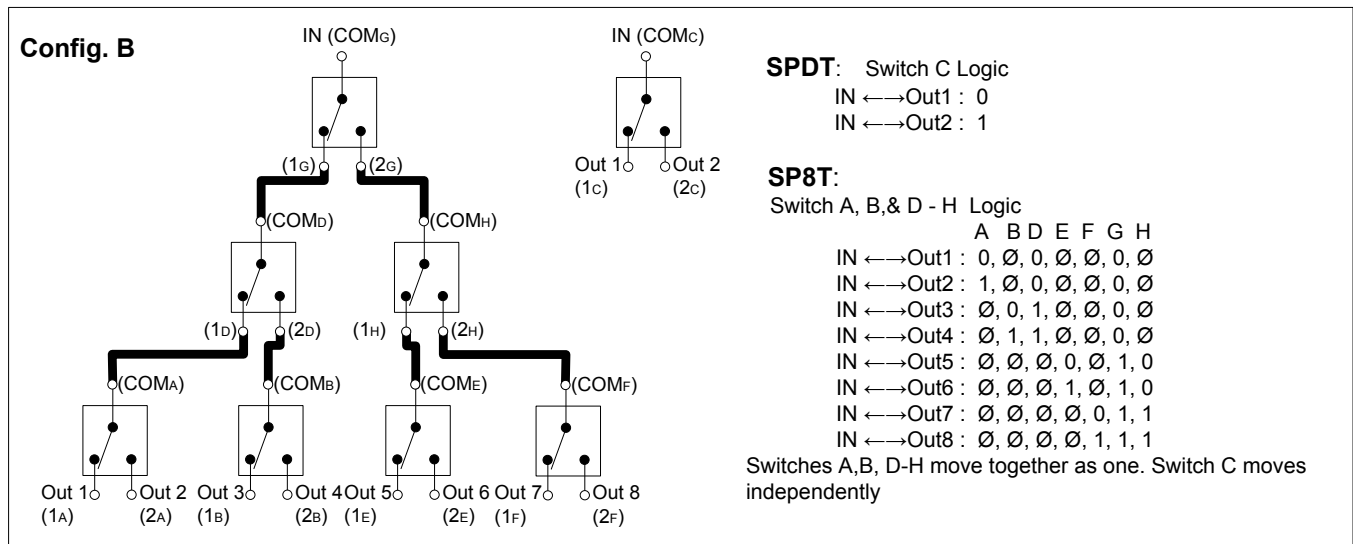
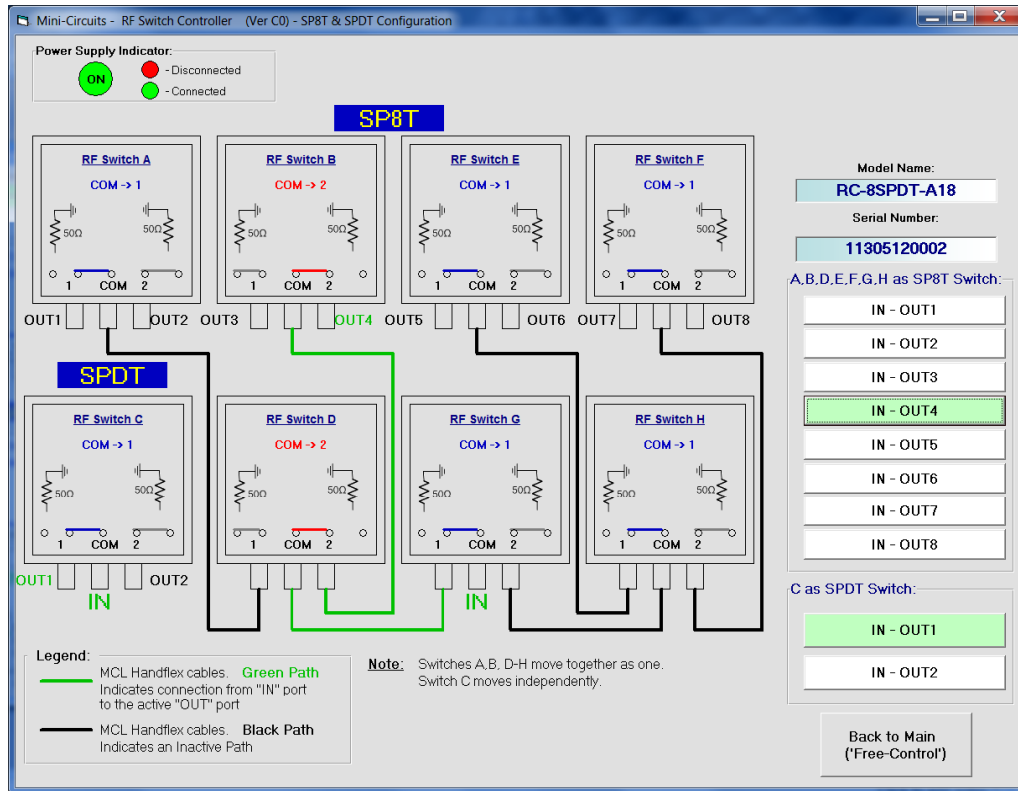

Configuration C: SP7T & SP3T switches

- Power handling is specified with RF applied to the COM port and output load connected to either 1 or 2 of the respective switch.
- When connecting a coaxial semi flex cable, tighten connectors alternately using an 8in/lb torque wrench to insure proper contact at each end.

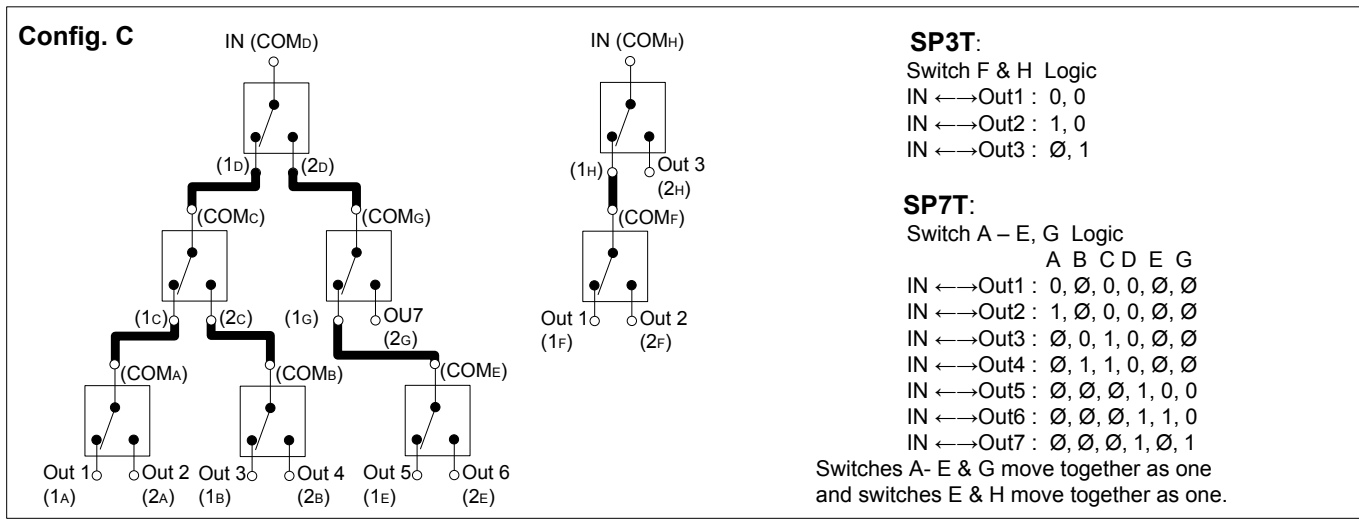
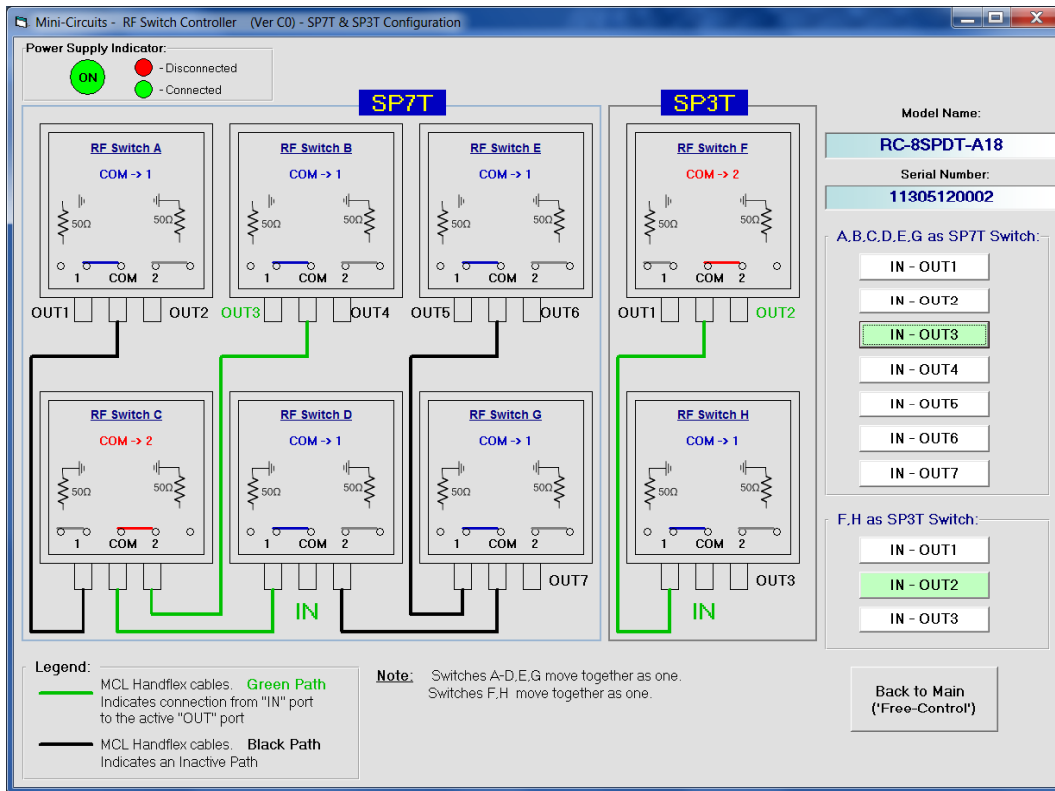

Configuration D: SP6T & SP4T switches

- Power handling is specified with RF applied to the COM port and output load connected to either 1 or 2 of the respective switch.
- When connecting a coaxial semi flex cable, tighten connectors alternately using an 8in/lb torque wrench to insure proper contact at each end.

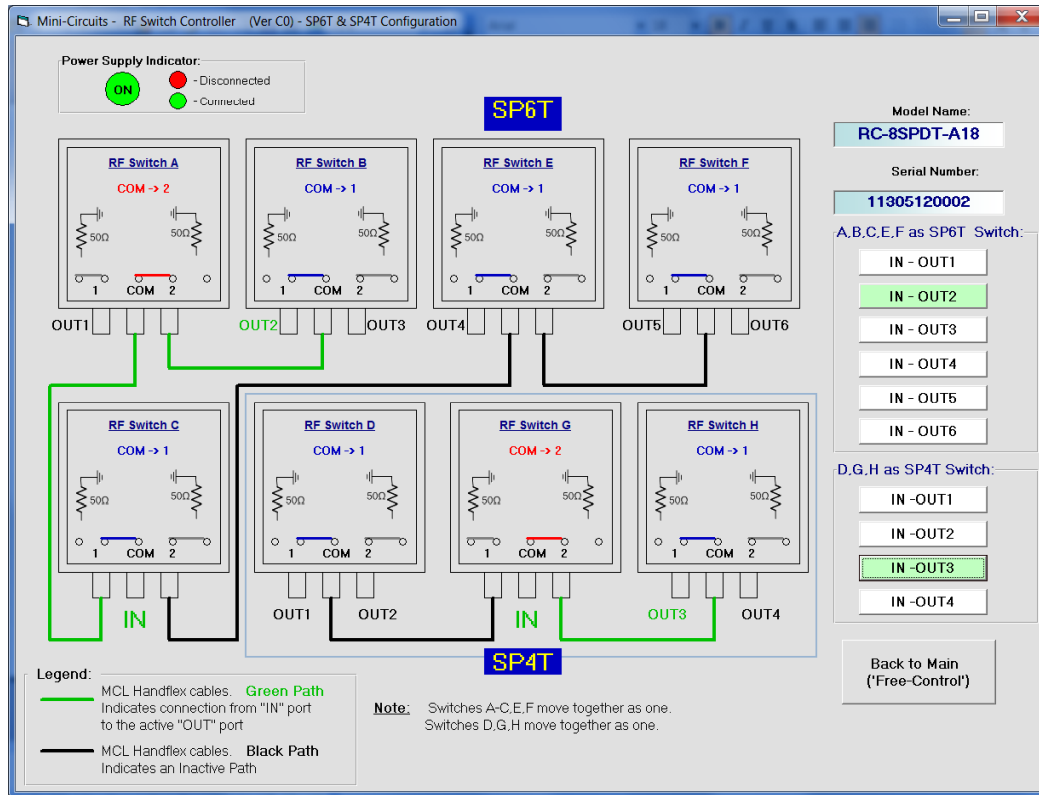

Config. D

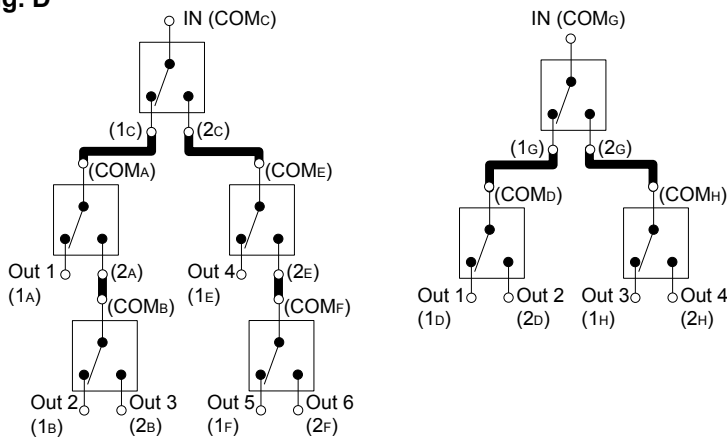

SP4T:

Switch D, G & H Logic

IN \leftrightarrow Out1 : 0, 0, \emptyset
 IN \leftrightarrow Out2 : 1, 0, \emptyset
 IN \leftrightarrow Out3 : \emptyset , 1, 0
 IN \leftrightarrow Out4 : \emptyset , 1, 1

SP6T:

Switch A, B, C, E & F Logic

A B C E F
 IN \leftrightarrow Out1 : 0, \emptyset , 0, \emptyset , \emptyset
 IN \leftrightarrow Out2 : 1, 0, 0, \emptyset , \emptyset
 IN \leftrightarrow Out3 : 1, 1, 0, \emptyset , \emptyset
 IN \leftrightarrow Out4 : \emptyset , \emptyset , 1, 0, \emptyset
 IN \leftrightarrow Out5 : \emptyset , \emptyset , 1, 1, 0
 IN \leftrightarrow Out6 : \emptyset , \emptyset , 1, 1, 1

Switches A, B, C, E & F move together as one and switches D,G & H move together as one.

Configuration E: Transfer switch & SP5T switch

- Power handling is specified with RF applied to the COM port and output load connected to either 1 or 2 of the respective switch.
- When connecting a coaxial semi flex cable, tighten connectors alternately using an 8in/lb torque wrench to insure proper contact at each end.

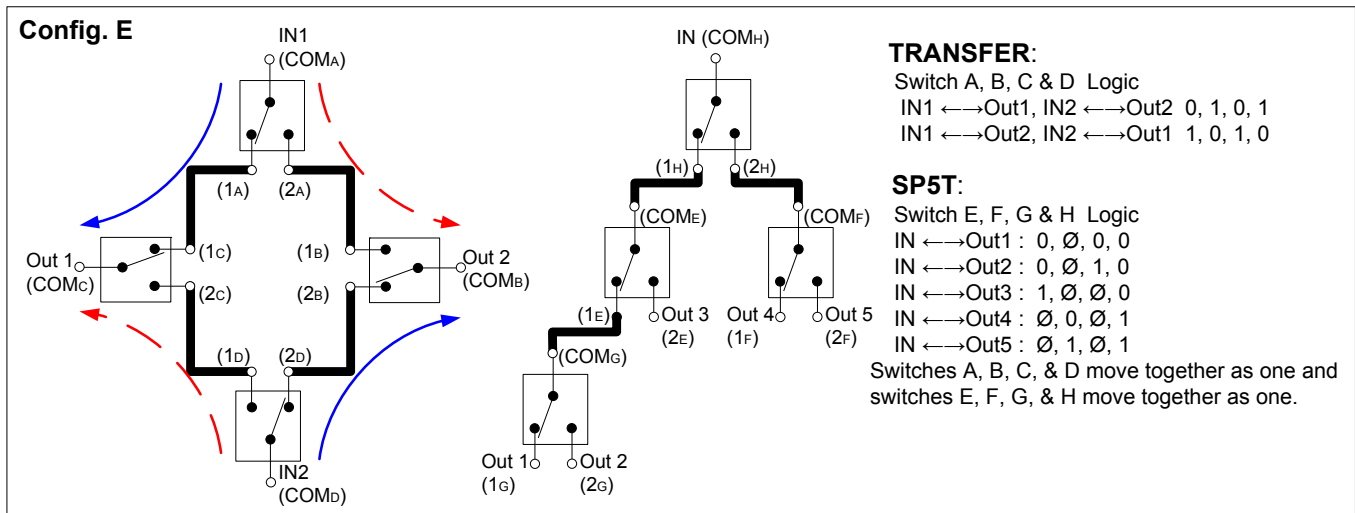
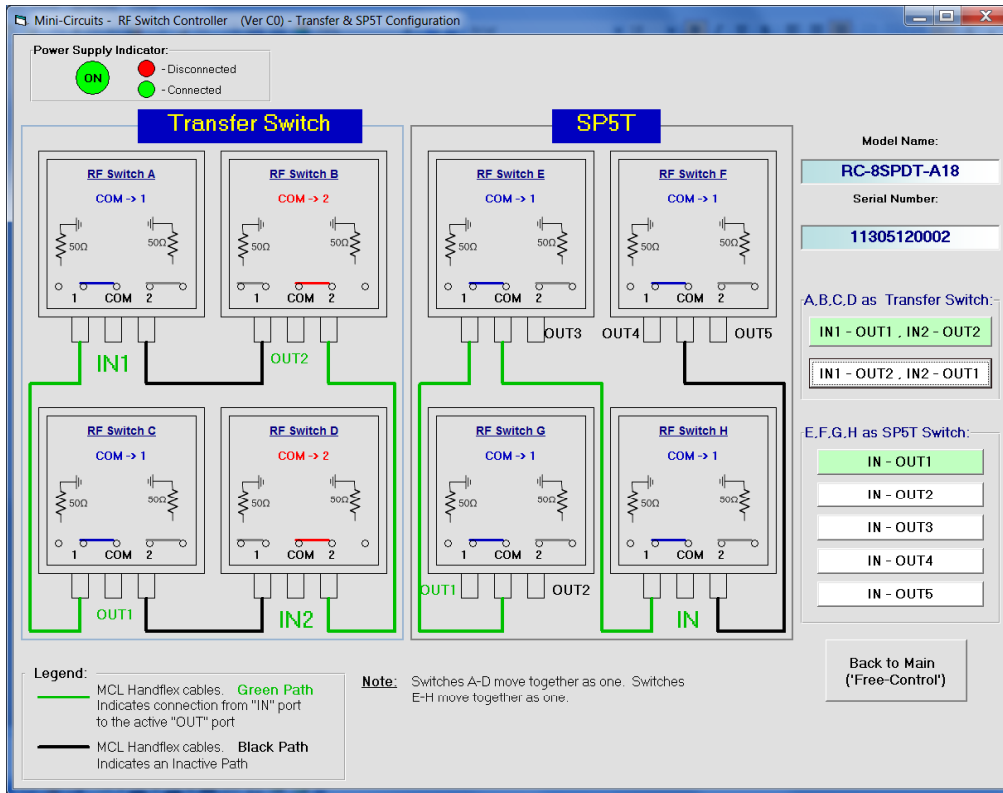

Configuration F: Dual 2x4 switches

- Power handling is specified with RF applied to the COM port and output load connected to either 1 or 2 of the respective switch.
- When connecting a coaxial semi flex cable, tighten connectors alternately using an 8in/lb torque wrench to insure proper contact at each end.

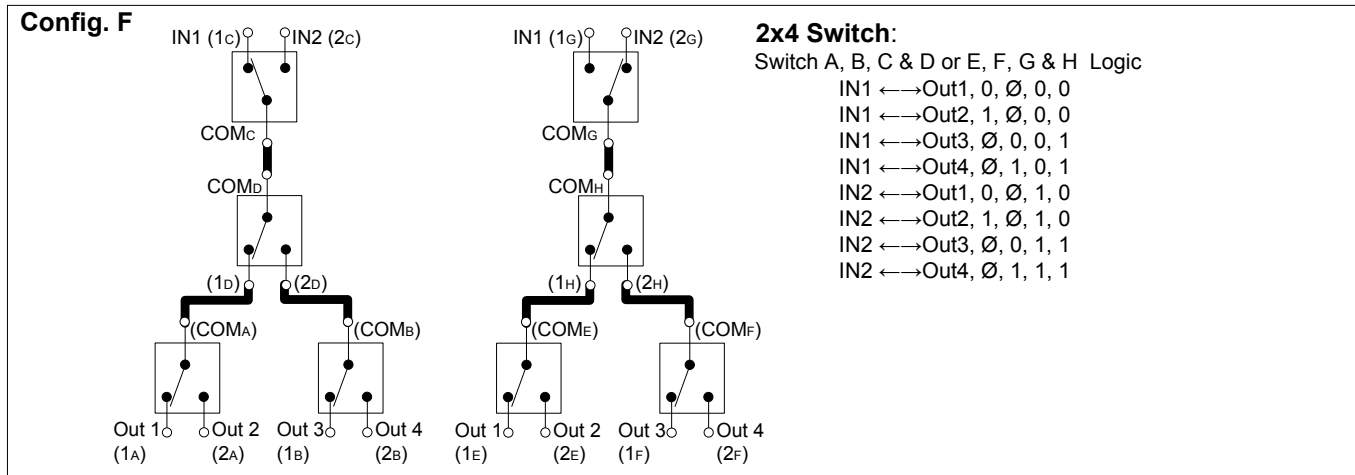
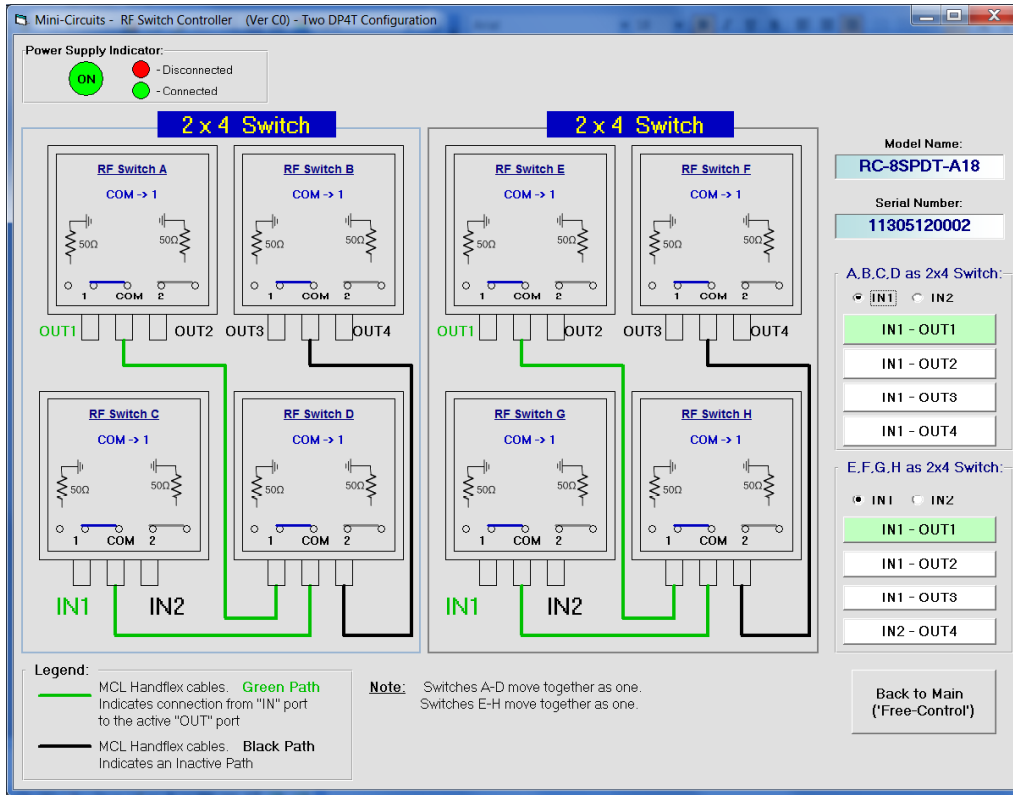

Configuration G: 2x8 switch

- Power handling is specified with RF applied to the COM port and output load connected to either 1 or 2 of the respective switch.
- When connecting a coaxial semi flex cable, tighten connectors alternately using an 8in/lb torque wrench to insure proper contact at each end.

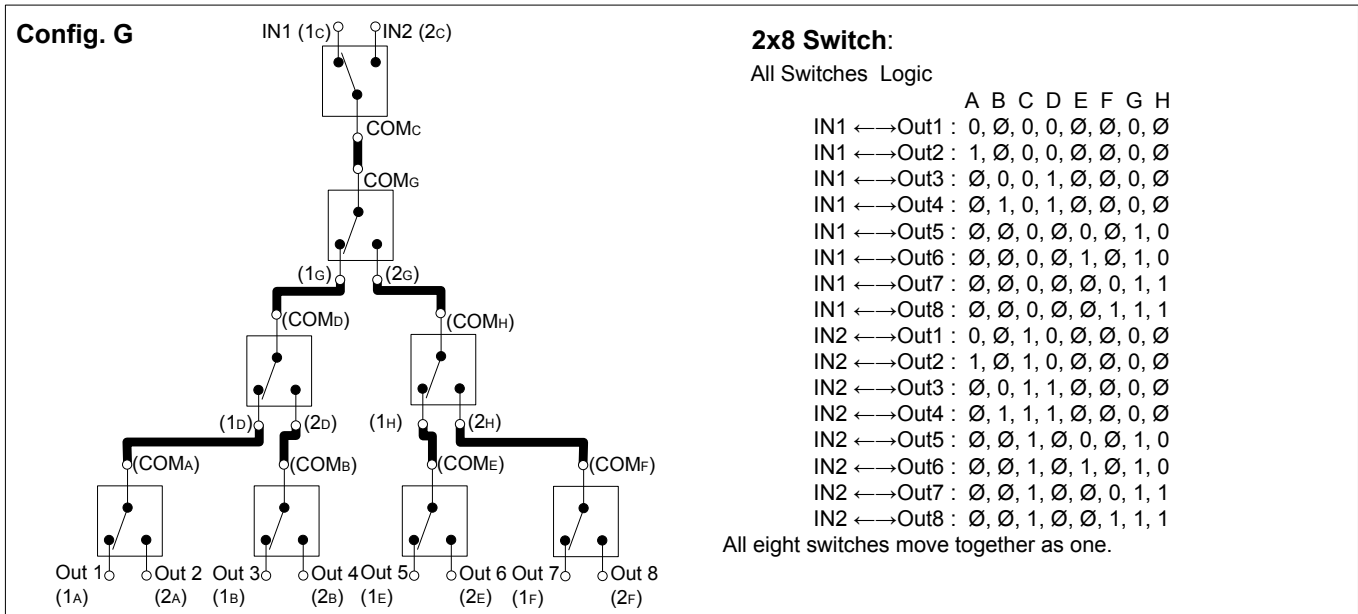
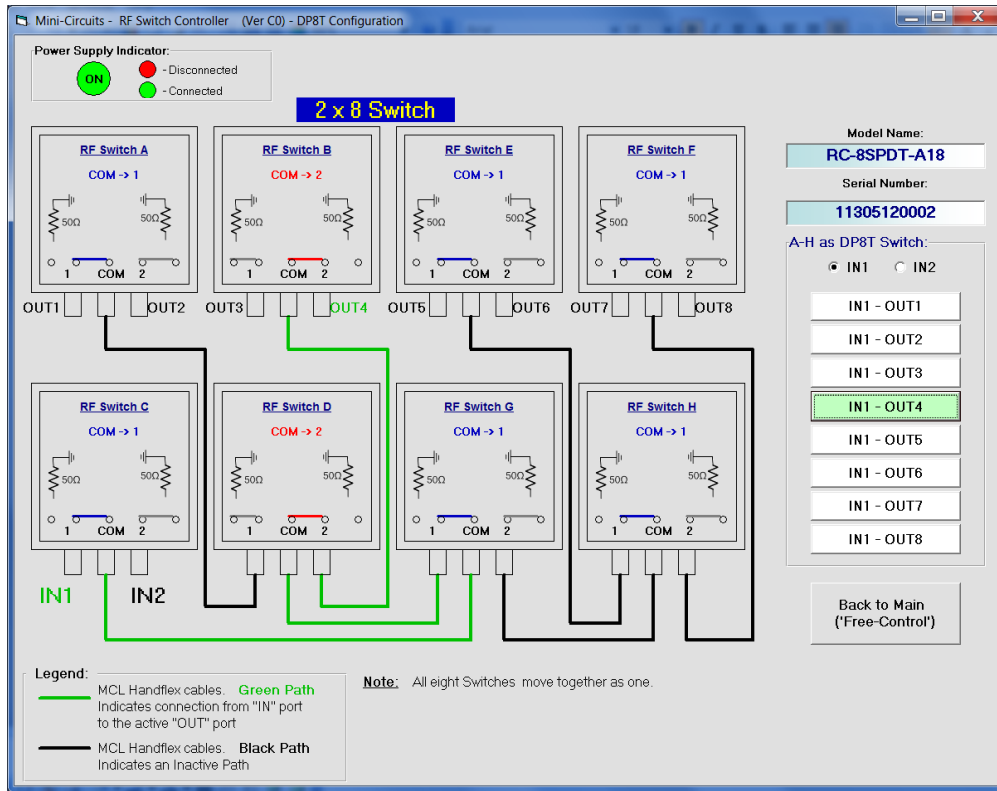

Configuration H: SP9T switch

- Power handling is specified with RF applied to the COM port and output load connected to either 1 or 2 of the respective switch.
- When connecting a coaxial semi flex cable, tighten connectors alternately using an 8in/lb torque wrench to insure proper contact at each end.

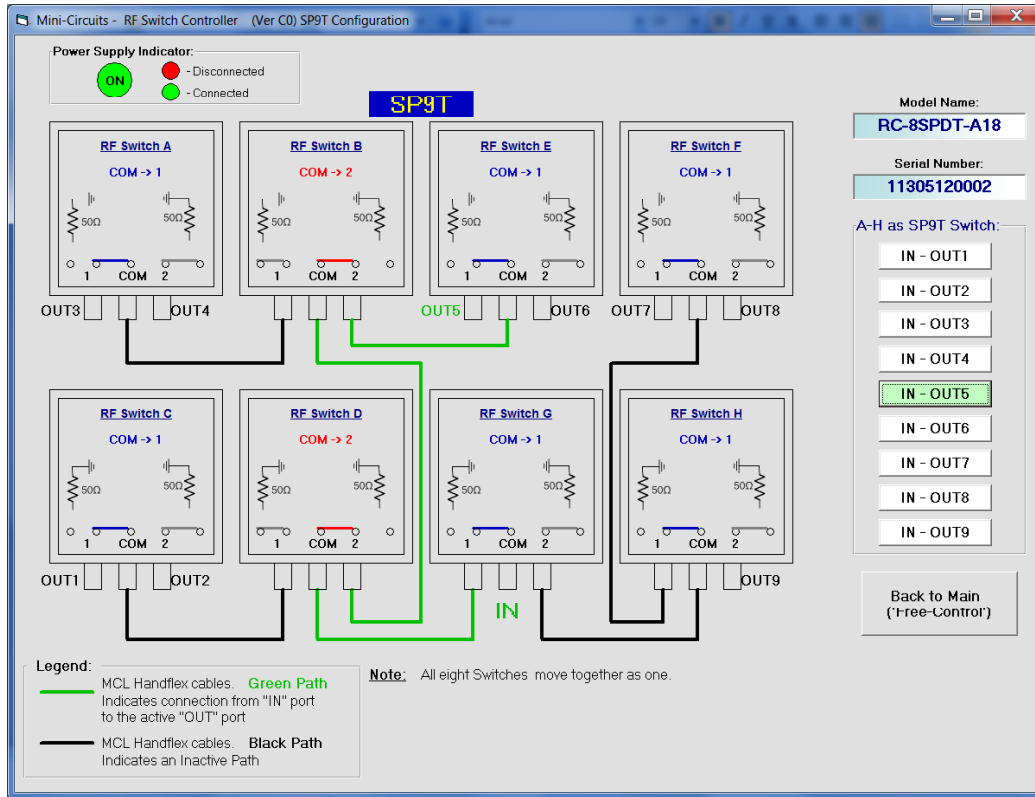

Config. H

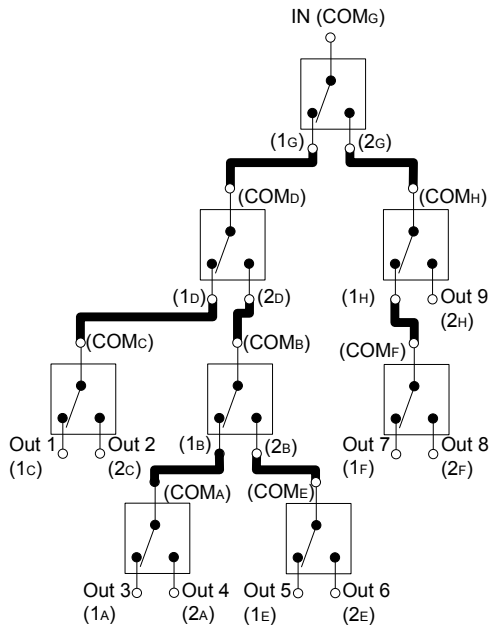

SP9T:
All Switches Logic

	A	B	C	D	E	F	G	H
IN ↔ Out1 :	∅	∅	0	0	∅	∅	0	∅
IN ↔ Out2 :	∅	∅	1	0	∅	∅	0	∅
IN ↔ Out3 :	0	0	∅	1	∅	∅	0	∅
IN ↔ Out4 :	1	0	∅	1	∅	∅	0	∅
IN ↔ Out5 :	∅	1	∅	1	0	∅	0	∅
IN ↔ Out6 :	∅	1	∅	1	1	∅	0	∅
IN ↔ Out7 :	∅	∅	∅	∅	∅	∅	0	1
IN ↔ Out8 :	∅	∅	∅	∅	∅	∅	1	1
IN ↔ Out9 :	∅	∅	∅	∅	∅	∅	1	1

All Switches move together as one.

Configuration J: 2x6 switch & SP3T switch

- Power handling is specified with RF applied to the COM port and output load connected to either 1 or 2 of the respective switch.
- When connecting a coaxial semi flex cable, tighten connectors alternately using an 8in/lb torque wrench to insure proper contact at each end.

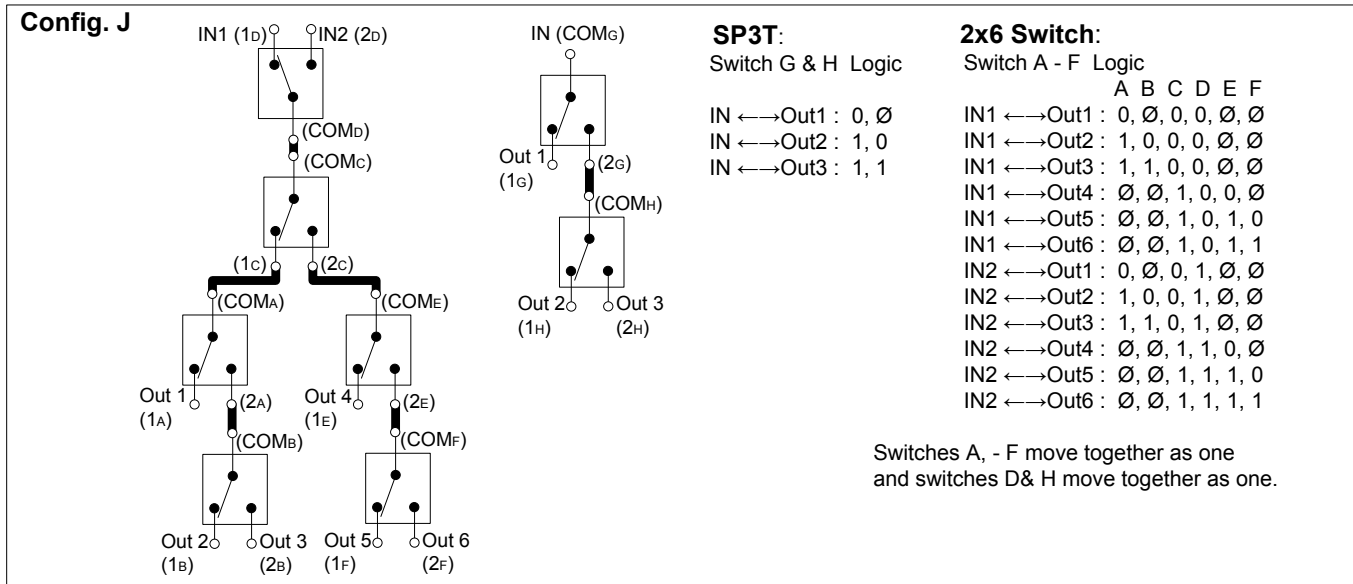
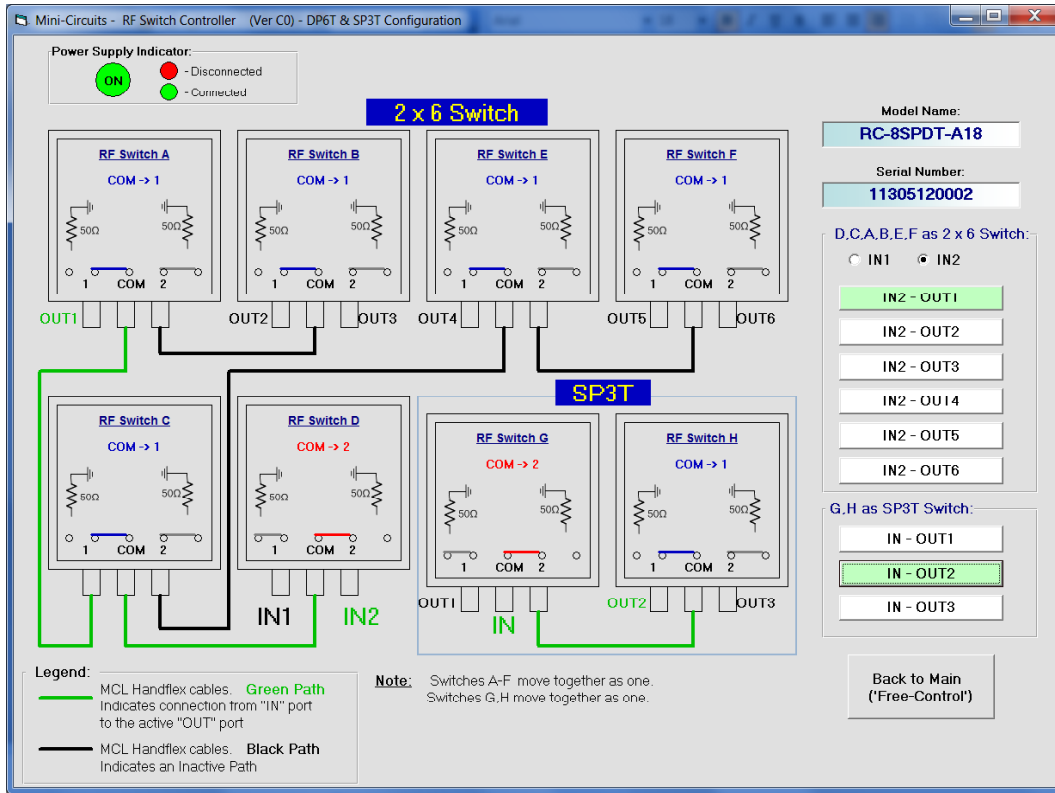

Configuration K: Dual Transfer switches

- Power handling is specified with RF applied to the COM port and output load connected to either 1 or 2 of the respective switch.
- When connecting a coaxial semi flex cable, tighten connectors alternately using an 8in/lb torque wrench to insure proper contact at each end.

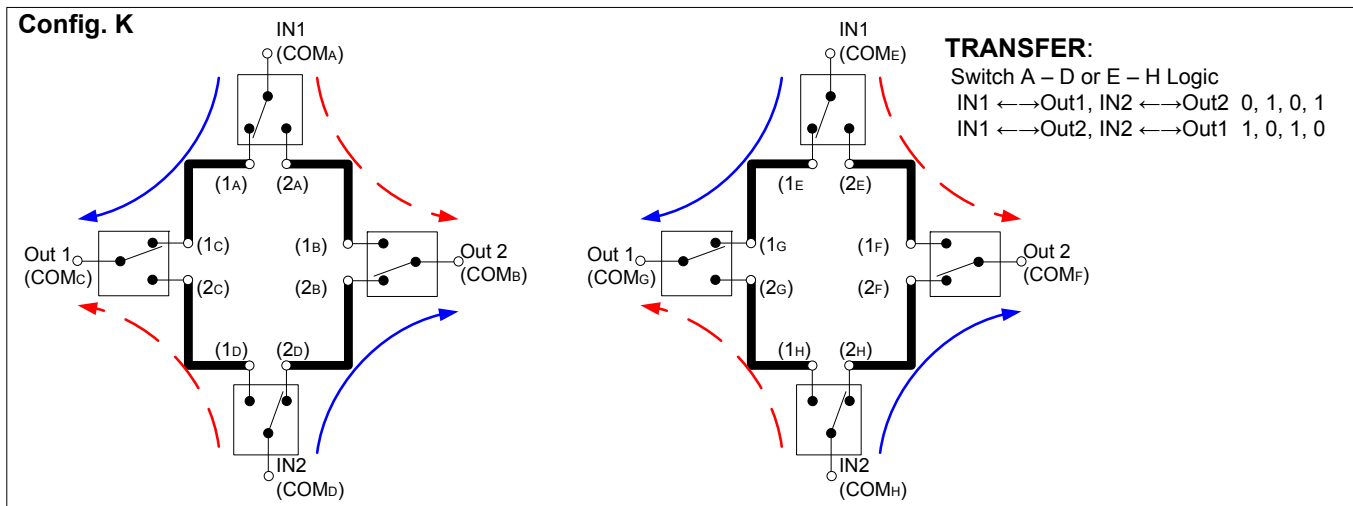
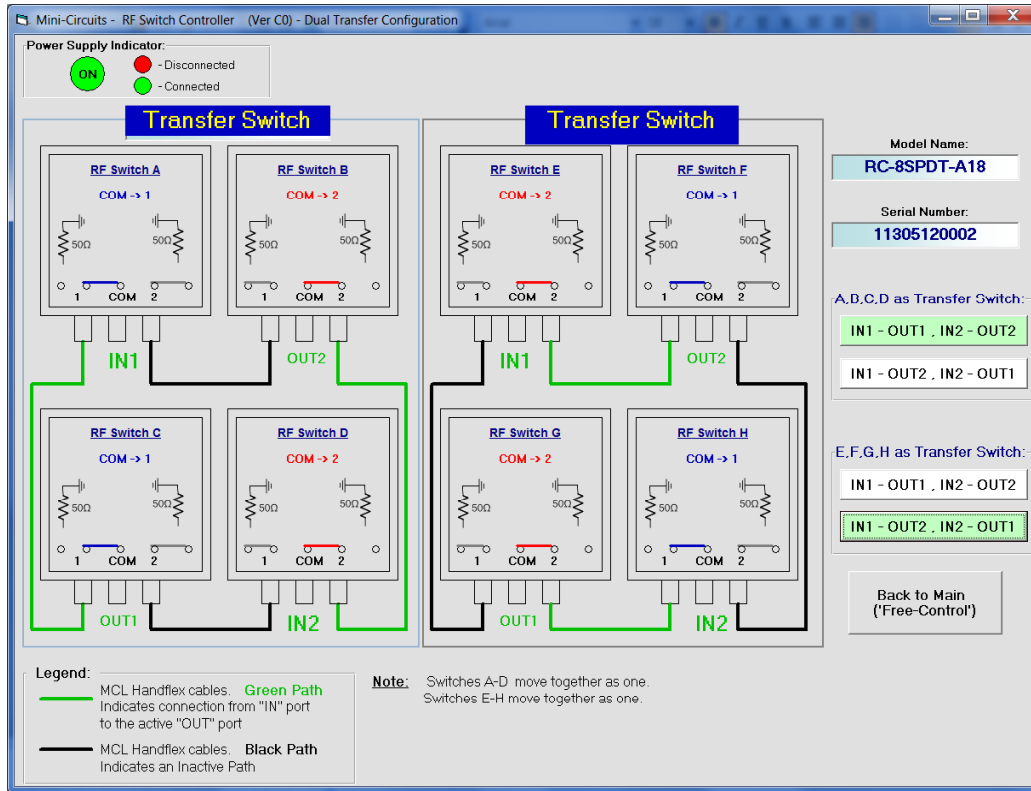

User Switching Sequence - for setting any configuration or sequence needed

- Power handling is specified with RF applied to the COM port and output load connected to either 1 or 2 of the respective switch.
- When connecting a coaxial semi flex cable, tighten connectors alternately using an 8in/lb torque wrench to insure proper contact at each end.

Mini-Circuits - RF Switch Controller (Ver C0)

Power Supply Indicator: ● ON ● - Disconnected ● - Connected

USER SWITCHING SEQUENCE

Model Name: **RC-8SPDT-A18** Serial Number: **11306120002**

Set Name: _____

Step	SW A	SW B	SW C	SW D	SW E	SW F	SW G	SW H	dwll (mSec)	Exec Program
Step 1	COM->1	COM->1	COM->1	COM->1	COM->1	COM->1	COM->1	COM->1	100	
Step 2	COM->2	COM->2	COM->1	COM->1	COM->1	COM->1	COM->1	COM->1	100	
Step 3	COM->2	COM->2	COM->1	COM->1	COM->1	COM->1	COM->2	COM->1	200	
Step 4	COM->2	COM->2	COM->1	COM->1	COM->2	COM->2	COM->2	COM->1	550	

Buttons: Add, Insert, Remove

Run Sequence:

Count Limit: 55 Counter: 2

Time Limit(min): _____ Elapsed (min): 0.07

Buttons: Current Step, Continuously, Stop

View Switches

Buttons: Back to Main ('Free-Control')

Check this box to show graphical presentation of current switch state (shown below)

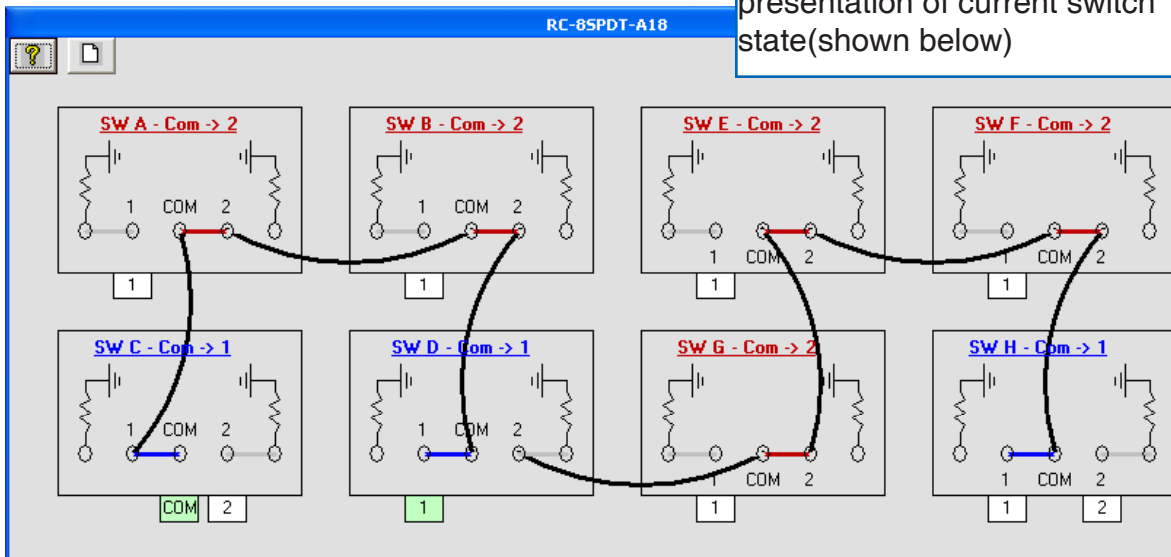

- For instructions on using the GUI See the [user guide](#) on Mini-Circuits' website
- For programming instructions of the switch matrix see the [programming guide](#) and [AN-49-001](#) on Mini-Circuits' website

Software & Documentation Download:

- Mini-Circuits' full software and support package including user guide, Windows GUI, DLL files, programming manual and examples can be downloaded free of charge from:
<https://www.minicircuits.com/softwaredownload/rfswitchcontroller.html>
- Please contact testsolutions@minicircuits.com for support.

Minimum System Requirements

Parameter	Requirements	
Interface	USB HID or HTTP Get/Post or Telnet protocols	
System requirements	GUI:	Windows 32 & 64 bit systems from Windows 98 up to Windows 10
	API DLL (USB)	Windows 32 & 64 bit systems with ActiveX or .Net support from Windows 98 up to Windows 10
	USB interrupt API	Linux, Windows systems from Windows 98 up to Windows 10
	Telnet & HTTP	Any Windows, Mac, or Linux computer with a network port and Ethernet-TCP/IP (HTTP or Telnet protocols) support
Hardware	Pentium® II or higher	

Graphical User Interface (GUI) for Windows

Key Features:

- Set each switch manually
- Set timed sequence of switching states
- Configure switch address and upgrade Firmware

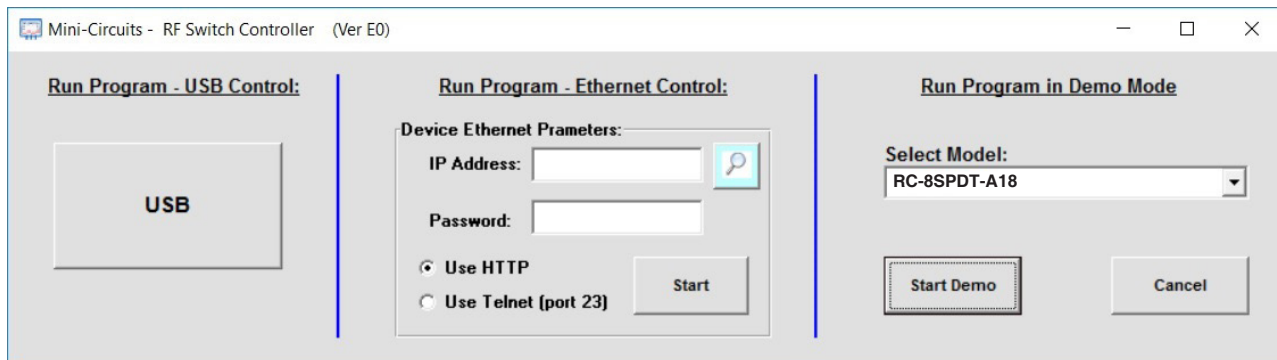

Steps to start RC-8SPDT-A18 GUI via USB

- Click on USB button.
- If more than one unit is connected select S/N from list and click OK.
- Start working.

Steps to start RC-8SPDT-A18 GUI via Ethernet

- Click on search icon.
- Select unit from list of IP addresses and click select
- The selected IP will appear in the IP Address field.
- Select communication protocol (Telnet or HTTP)
- Click on Start and begin working.

Application Programming Interface (API)

Windows Support:



- API DLL files exposing the full switch matrix functionality.
 - ActiveX COM DLL file for creation of 32-bit programs
 - .Net library DLL file for creation of 32 / 64-bit programs
- HTTP Get/Post and Telnet protocols use SCPI commands to provide full control.
- Supported by most common programming environments (refer to application note [AN-49-001](#) for summary of tested environments)





Linux Support:

- Full switch matrix control in a Linux environment is achieved by way of USB interrupt commands. See programming manual at https://www.minicircuits.com/softwaredownload/Prog_Manual-2-Switch.pdf for details

Ordering, Pricing & Availability Information see our web site

Model	Description
RC-8SPDT-A18	USB/Ethernet RF SPDT Switch Matrix

Included Accessories	Part No.	Description
	AC/DC-24-3W1	AC/DC 24V _{DC} Grounded Power Adaptor. Operating temperature: 0°C to +40°C, I _{Max} =2.5A
	CBL-3W1-XX	AC Power Cord (Select one power cord from below with each Switch Matrix box)
	USB-CBL-AB-3+	2.7 ft (0.8 m) USB Cable: USB type A(Male) to USB type B(Male)

AC Power Cords ⁵	Part No.	Description
	CBL-3W1-US	Power Cord for United States
	CBL-3W1-EU	Power Cord for Europe
	CBL-3W1-UK	Power Cord for United Kingdom
	CBL-3W1-AU	Power Cord for Australia and China
	CBL-3W1-IL	Power Cord for Israel

⁵ Power cords for other countries are also available, if you need a power cord for a country not listed in the table please contact testsolutions@minicircuits.com.

Optional Accessories	Description
USB-CBL-3+ (spare)	2.7 ft (0.8 m) USB Cable: USB type A(Male) to USB type B(Male)
USB-CBL-7+	6.8 ft (2.1 m) USB Cable: USB type A(Male) to USB type B(Male)
USB-CBL-11+	11 ft (3.4 m) USB Cable: USB type A(Male) to USB type B(Male)
CBL-RJ45-MM-5+	5 ft (1.5 m) Ethernet cable: RJ45(Male) to RJ45(Male) Cat 5E cable
BKT-272-08+	Bracket (One set of 2 each)

Additional Notes

- Performance and quality attributes and conditions not expressly stated in this specification document are intended to be excluded and do not form a part of this specification document.
- Electrical specifications and performance data contained in this specification document are based on Mini-Circuit's applicable established test performance criteria and measurement instructions.
- The parts covered by this specification document are subject to Mini-Circuits standard limited warranty and terms and conditions (collectively, "Standard Terms"); Purchasers of this part are entitled to the rights and benefits contained therein. For a full statement of the Standard Terms and the exclusive rights and remedies thereunder, please visit Mini-Circuits' website at www.minicircuits.com/MCLStore/terms.jsp